

TABLE OF CONTENTS

	Page
1. INTRODUCTION	2
2. SAFETY INSTRUCTION	3
3. PUSHBUTTON CONFIGURATION	
3.1 Alpha 500 & 520 Models	4
3.2 Alpha 540 & 560 Models	5
3.3 Alpha 580 Models	6
4. TRANSMITTER OUTLINE	
4.1 Alpha 500 & 520 Models	7
4.2 Alpha 540 & 560 Models	8
4.3 Alpha 580 Models	9
5. RECEIVER OUTLINE	
5.1 Alpha 500 ~ 560 Models External Assembly	10
5.2 Alpha 500 & 520 Models Internal Assembly	11
5.3 Alpha 540 & 560 Models Internal Assembly	12
5.4 Alpha 580 Models External Assembly	13
5.5 Alpha 580 Models Internal Assembly	14
6. OUTPUT CONTACT DIAGRAMS	
6.1 Alpha 500 & 520 Models	15
6.2 Alpha 540 Models	16
6.3 Alpha 560 Models	17
6.4 Alpha 580 Models	18~20
7. SYSTEM CONFIGURATIONS	
7.1 How to Set Jumper Functions	21~22
7.2 How to Set ID Codes	22
7.3 Receiver RF Channel Setting	23
7.4 How to Remove the Transmitter RF Board	23
7.5 Alpha 580 Pushbutton Function Settings	24~25
7.6 Frequency (RF) Channel Table	26
8. RECEIVER INSTALLATION	
8.1 Preparation For Installation	27
8.2 Step By Step Installation	27
8.3 System Testing	28
9. TRANSMITTER OPERATION	29~31
10. TROUBLE SHOOTING	32
11. SYSTEM SPECIFICATION	33
12. PARTS LIST	34~35

1. INTRODUCTION

The Alpha 500 series are highly durable, reliable and safe industrial radio remote control systems. The versatile features of the Alpha 500 series permit their use in many different remote control applications. The systems can be used to control factory cranes, monorail systems, multiple hoists, trolleys, mining equipment, building construction equipment, automatic control systems, and many others.

The system incorporates numerous redundant safety circuits that guaranty maximum security and ensure the system is resistant to outside interference. The major features of the Alpha 500 series are as follow:

- * The system uses advanced microprocessors with highly evolved software that has redundant error checking and correcting capabilities to ensure 100% error-free transmission, decoding, and control of all output relays. This highly evolved software includes CRC (Cyclical Redundancy Check Code) and Hamming Codes (Error Recovery) programming.
- * To insure maximum operating safety, the Alpha 500 series incorporates numerous important safety features. Some of these built in safety features include transmitter pushbutton self-diagnosing during initial startup, transmitter low-voltage detection and visual warning with additional output for external warning light connection (LV relay), receiver self-diagnosing, MAIN deactivation during transmitter low-voltage, when system is in sleep mode, when system encountering strong RF interference, and when the transmitter is out of the receiving range.
- * The transmitter encoder and receiver decoder both utilize advanced microprocessor control. The availability of 32,768 sets of unique ID codes + 20 distinct RF channels will ensure that only commands from the matching control transmitter can be carried out without any interference from other radio systems.
- * For added safety, the system also incorporates special type of safety MAIN contact relay or relays. If the safety MAIN relay becomes defective (fails to open or close during operation or not responding to a “stop” command), it will signal the system to shut down immediately to avoid the possibility of any accidents occurring.
- * 20 sets of user-adjustable receiving RF channels plus special designed removable transmitting RF board for easy channel replacement and service maintenance.
- * Waterproofed transmitter and receiver enclosures, including the battery compartment.

The Alpha 500 series radio remote control systems consist of water-resistant IP-66 transmitters and IP-65 / IP-66 receivers. All receiver s are equipped with a 2-meter pre-wired output cable (Alpha 500 ~ 560 models). The transmitter casings are molded using industrial strength composite materials which are impervious to dust, water, oil, acids, alkaline, heat and sunlight as well as being resistant to deformation due to long term use in harsh environments. The pushbuttons are also constructed from industrial strength composite materials with minimum of up to one million press cycles. For battery power savings, the transmitter is designed and manufactured with a special ultra-efficiency power-saving circuit that requires only two “AA” size alkaline batteries for more than 150 hours of continuous operation.

2. SAFETY INSTRUCTION

The Alpha 500 series are relatively simple to use, however, it is very important to observe the proper safety procedures before, during, and after operation. When used properly, the Alpha 500 series will enhance safety, productivity and efficiency in the workplace.

The following procedures should be strictly followed:

1. Check the transmitter casing and pushbuttons daily. Should any damage that could inhibit the proper operation of the transmitter be found the unit should be immediately removed from service.
2. The transmitter voltage should be checked on a daily basis. If the voltage is low (red status light blinking or completely off), the two “AA” alkaline batteries should be replaced.
3. The red emergency stop button (EMS) should be checked at the beginning of each shift to ensure it is in proper working order and the “Stop” command is being received by the receiver.
4. In the event of an emergency press down the EMS button will immediately deactivates the receiver MAIN relay and the transmitter power. Then turned the power “off ” from the main power source to the crane or equipment.
5. The transmitter power switch should be turned off after each use and should never be left in the “power on” state when the unit is unattended.
6. Do not use the same RF channel and ID code as any other system in use at the same facility or within 300-meter distance.
7. Ensure the wrist strap (Alpha 500 ~ 560 models) or the waist belt (Alpha 580 models) is worn at all time during operation to avoid accidental damage to the transmitter.
8. Never operate a crane or equipment with two transmitters at the same time with the same RF channel and ID code, as it will cause radio interference.

Caution!

Improper Storage of your Spare Transmitter is a Safety Hazard! During the initial installation of your remote control system the spare (second) transmitter should be tested to confirm that it is functioning properly and then the batteries must be removed and the transmitter stored in a secured place. Failure to follow this safety procedure can result in the inadvertent operation of your crane or hoist by unauthorized personnel resulting in serious injury or death!

3. PUSHBUTTON CONFIGURATION

3.1 Alpha 500 & 520 Models

1. Alpha 500 : (4) one-speed pushbuttons.
2. Alpha 520 : (4) two-speed pushbuttons.

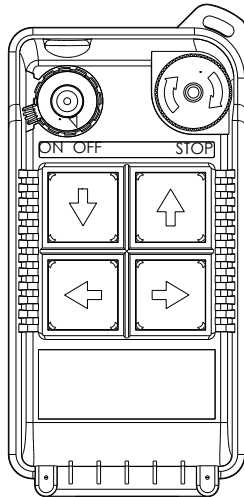

(Alpha 500)

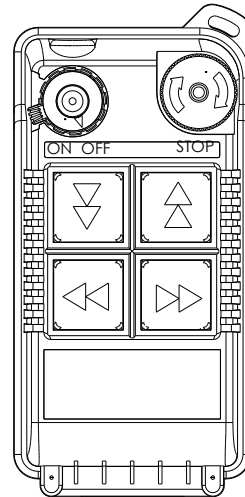

(Alpha 520)

Below are some of many types of pushbutton configurations that are also available, please contact your dealer for more details.

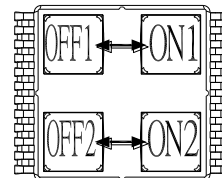
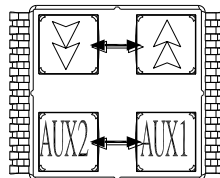
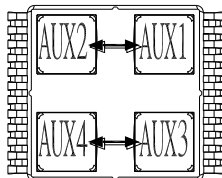
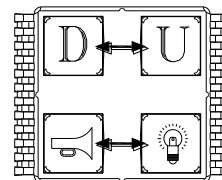
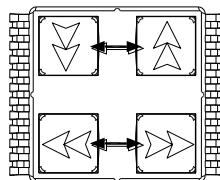
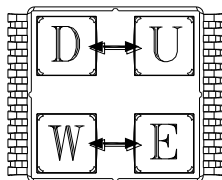

↔ Interlocked (Can also be set to non-interlocked via an external programmer unit).

3.2 Alpha 540 & 560 Models

1. Alpha 540S : (6) one-speed pushbuttons.
2. Alpha 540A : (6) one-speed pushbuttons + (1) AUX micro-button.
3. Alpha 540T : (6) one-speed pushbuttons + (1) AUX selector switch.
4. Alpha 560S : (6) two-speed pushbuttons.
5. Alpha 560A : (6) two-speed pushbuttons + (1) AUX micro-button.
6. Alpha 560T : (6) two-speed pushbuttons + (1) AUX selector switch.

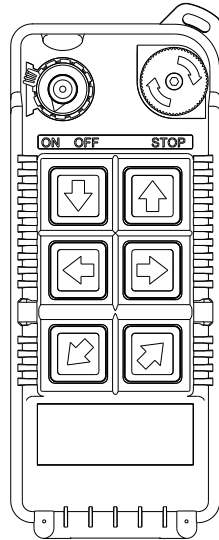

(Alpha 540S)

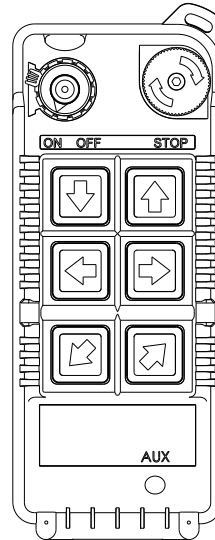

(Alpha 540A)

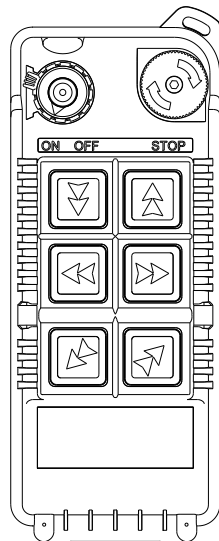

(Alpha 560S)

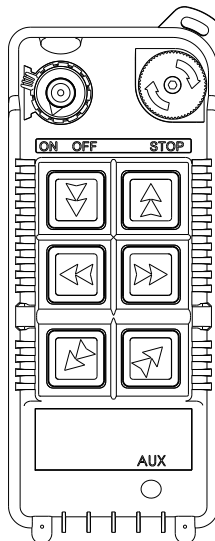

(Alpha 560A)

3.3 Alpha 580 Models

1. Alpha 580A-1 : (10) one-speed pushbuttons (labeled as 3 motions).
2. Alpha 580A-2 : (10) one-speed pushbuttons (labeled as 4 motions).
3. Alpha 580B : (9) one-speed pushbuttons + (1) SELECT I/II pushbutton.*
4. Alpha 580C-1 : (6) two-speed + (4) one-speed pushbuttons.
5. Alpha 580C-2 : (8) two-speed + (2) one-speed pushbuttons.
6. Alpha 580D+1 : (10) two-speed pushbuttons + (1) AUX micro-button.
7. Alpha 580E : (6) two-speed + (3) one-speed pushbuttons + (1) SELECT I/II pushbutton.*
8. Alpha 580F : (8) two-speed + (1) one-speed pushbutton + (1) SELECT I/II pushbutton.*

* For cranes with auxiliary hoist and trolley (changeover function).

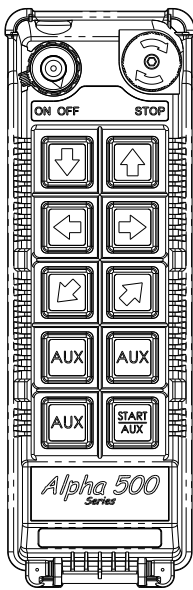

(Alpha 580A-1)

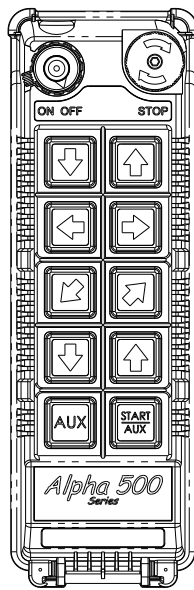

(Alpha 580A-2)

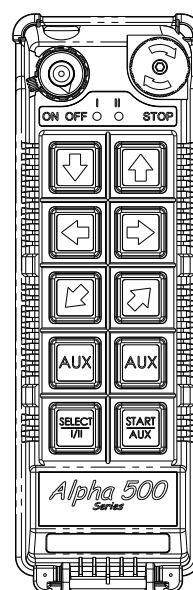

(Alpha 580B)

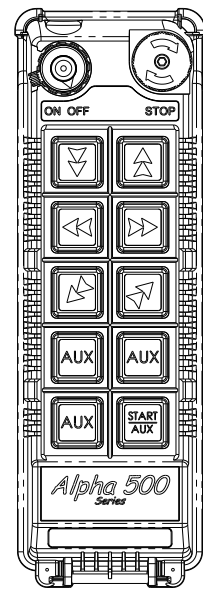

(Alpha 580C-1)

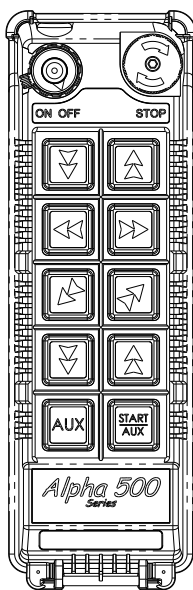

(Alpha 580C-2)

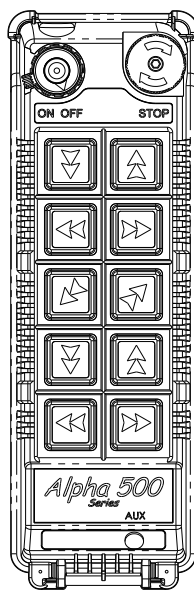

(Alpha 580D+1)

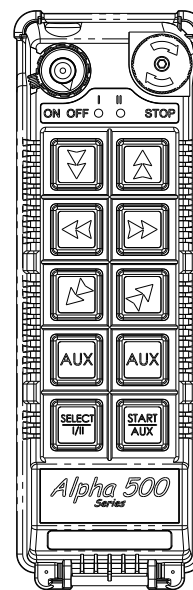

(Alpha 580E)

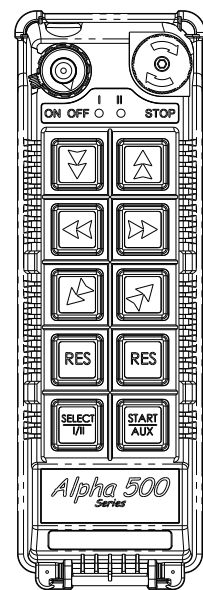

(Alpha 580F)

4. TRANSMITTER OUTLINE

4.1 Alpha 500 & 520 Models

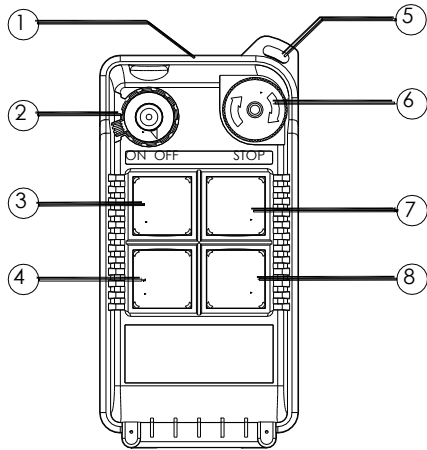

(Fig. 1) Front View

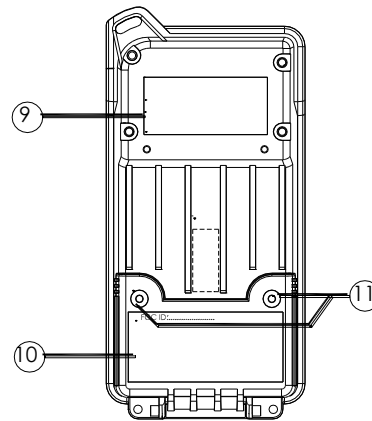

(Fig. 2) Back View

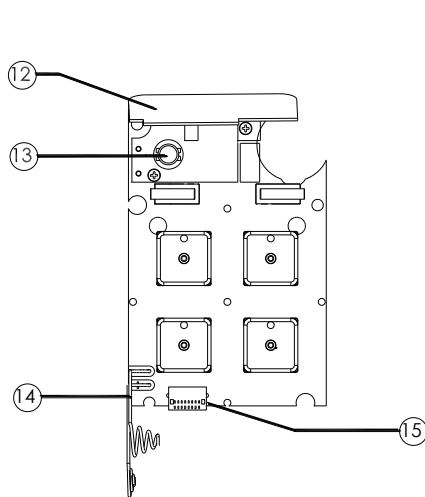

(Fig. 3) Front View

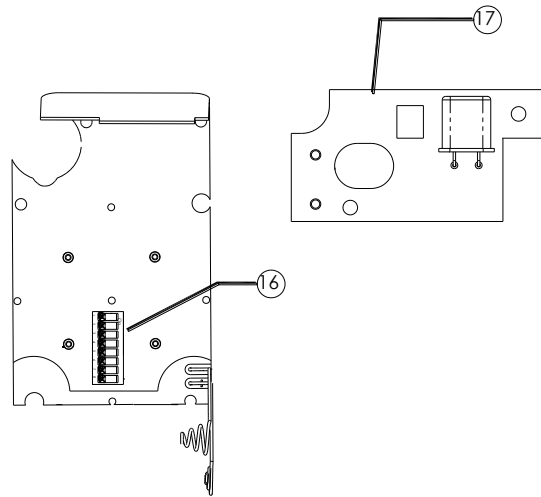

(Fig. 4) Back View

- | | | |
|-----------------------------|------------------------------|---------------------------|
| 1) Transmitter enclosure | 8) Pushbutton # 3 (→ / East) | 15) Programming port |
| 2) Power switch (ON/OFF) | 9) System information | 16) ID code dip-switch |
| 3) Pushbutton #2 (↓ / Down) | 10) Battery cover | 17) Transmitting RF Board |
| 4) Pushbutton #4 (← / West) | 11) Battery cover screws | |
| 5) Wrist strap attachment | 12) Internal antenna | |
| 6) Emergency stop (EMS) | 13) Status LED display | |
| 7) Pushbutton #1 (↑ / Up) | 14) Battery contact | |

4.2 Alpha 540 & 560 Models

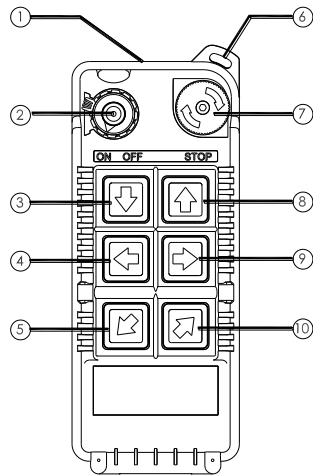

(Fig. 5) Front View

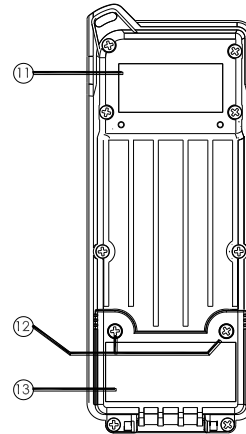

(Fig. 6) Back View

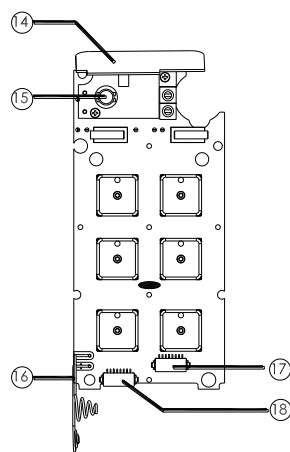

(Fig. 7) Front View

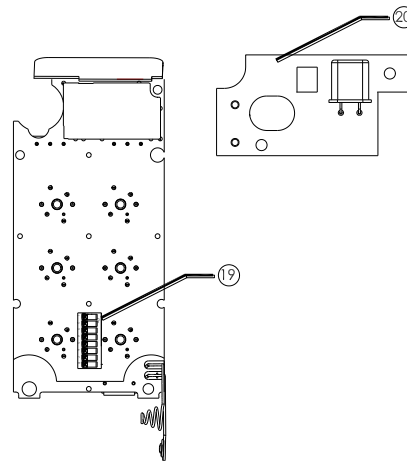

(Fig. 8) Back View

- | | | |
|------------------------------|-------------------------------|---------------------------------|
| 1) Transmitter enclosure | 8) Pushbutton #1 (↑ / Up) | 15) Status LED display |
| 2) Power switch (ON/OFF) | 9) Pushbutton #3 (→ / East) | 16) Battery contact |
| 3) Pushbutton #2 (↓ / Down) | 10) Pushbutton #5 (↗ / North) | 17) AUX micro-button connector* |
| 4) Pushbutton #4 (← / West) | 11) System information | 18) Programming port |
| 5) Pushbutton #6 (↙ / South) | 12) Battery cover screws | 19) ID code dip-switch |
| 6) Wrist strap attachment | 13) Battery cover | 20) Transmitting RF board |
| 7) Emergency stop (EMS) | 14) Internal antenna | |

* For Alpha 540A and Alpha 560A models only.

4.3 Alpha 580 Models

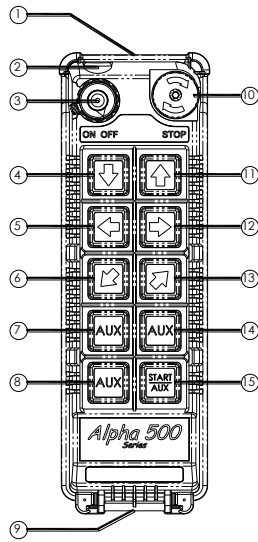

(Fig. 9) Front View

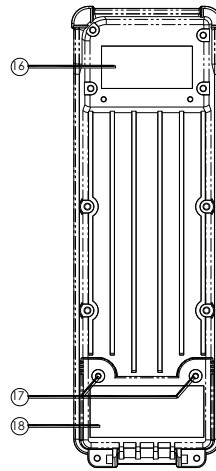

(Fig. 10) Back View

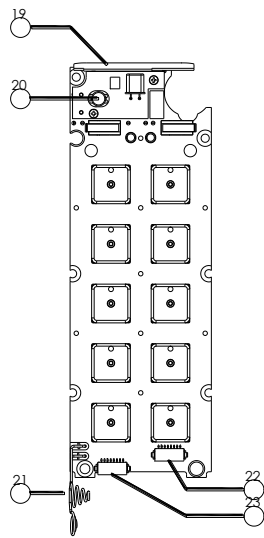

(Fig. 11) Front View

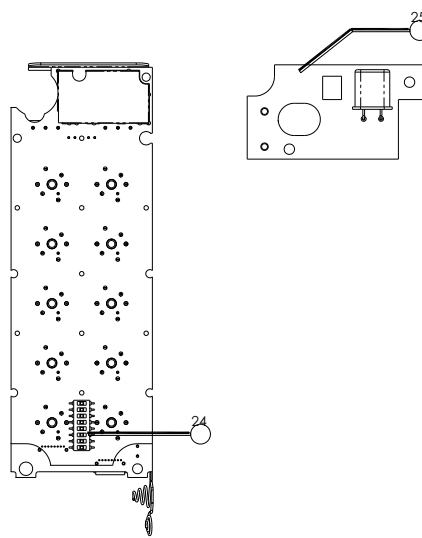

(Fig. 12) Back View

- | | | |
|------------------------------|-------------------------------|---------------------------------|
| 1) Transmitter enclosure | 9) Waist belt attachment | 17) Battery cover screws |
| 2) External antenna port | 10) Emergency stop (EMS) | 18) Battery cover |
| 3) Power switch (ON/OFF) | 11) Pushbutton #1 (↑ / Up) | 19) Internal antenna |
| 4) Pushbutton #2 (↓ / Down) | 12) Pushbutton #3 (→ / East) | 20) Status LED display |
| 5) Pushbutton #4 (← / West) | 13) Pushbutton #5 (↗ / North) | 21) Battery contact |
| 6) Pushbutton #6 (↙ / South) | 14) Pushbutton #7 (A1) | 22) AUX micro-button connector* |
| 7) Pushbutton #8 (A2) | 15) Pushbutton #9 (A3) | 23) Programming port |
| 8) Pushbutton #10 (A4) | 16) System information | 24) ID code dip-switch |
| | | 25) Transmitting RF board |

* For optional AUX micro-button or buttons.

5. RECEIVER OUTLINE

5.1 Alpha 500 ~ 560 Models External Assembly

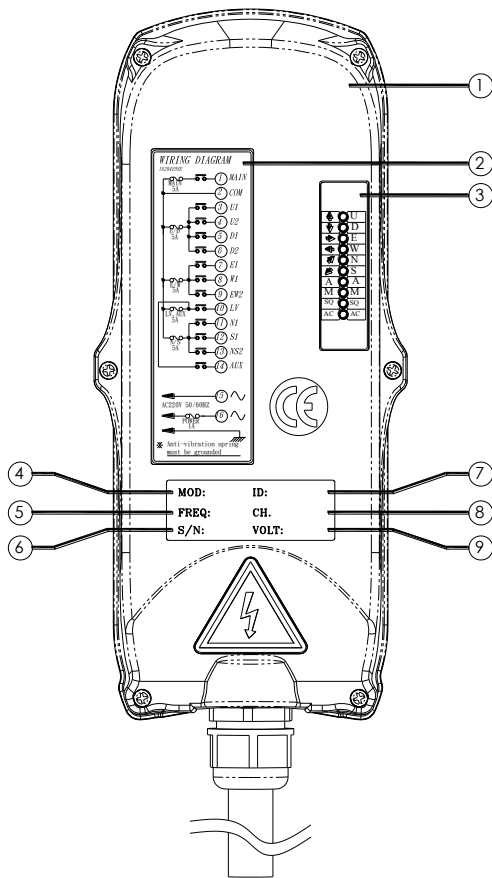

(Fig. 13) Front View

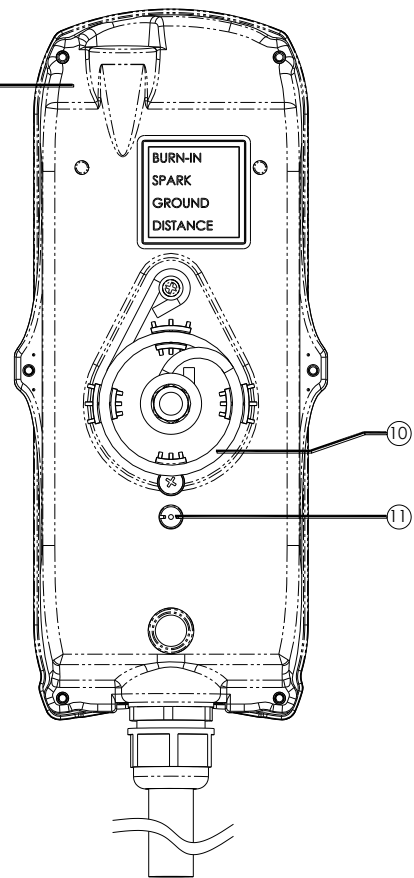

(Fig. 14) Back View

- | | | |
|---------------------------|-------------------------|---------------------------|
| 1) Receiver enclosure | 5) System frequency | 9) Supplied voltage |
| 2) Wiring diagram | 6) System serial number | 10) Anti-vibration spring |
| 3) Receiver LED displays* | 7) System ID code | 11) Grounding (GND) |
| 4) Type model | 8) System RF channel | |

* **A** ~ AUX Relay Contact Indicator (for Alpha 540A/560A models only).

* **M** ~ MAIN and 2nd Speed Relay Contact Indicator.

Green "on" → MAIN activated (All models).

Red "on" → 2nd speed activated (for Alpha 560S/A models only).

* **SQ** ~ RF Signal Indicator (Red).

"on" → RF signal detected and received.

"off" → No RF signal detected or received.

Blinking at transmitter power "off" → Other radio interference.

* **AC** ~ Power Source Indicator (red) "on" → AC input power supplied.

"off" → No AC input power.

5.2 Alpha 500 & 520 Models Internal Assembly

(Fig. 15) Internal Parts Assembly

- 1) Receiving RF module
- 2) Secondary power AC fuse (0.50A)
- 3) Primary power AC fuse (1.0A)
- 4) System status LED display*
- 5) External antenna port
- 6) ID code dip-switch
- 7) RF channel dip-switch
- 8) Contact relay LED display
- 9) Pushbutton #1 and #2 fuse (5.0A)
- 10) MAIN fuse (5.0A)
- 11) Contact output seat (CN3)
- 12) Low-voltage (LV) fuse (5.0A)
- 13) Contact output seat (CN4)
- 14) Pushbutton #3 and #4 fuse (5.0A)
- 15) AC power input seat (CN2)
- 16) Cable gland & output cable

* Please refer to page 32 for system status LED display information.

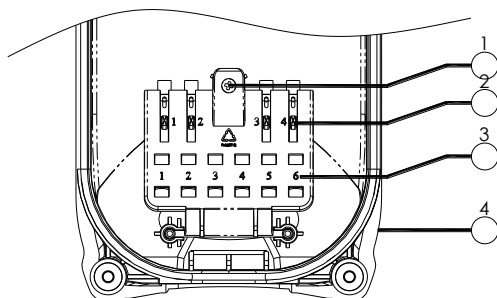
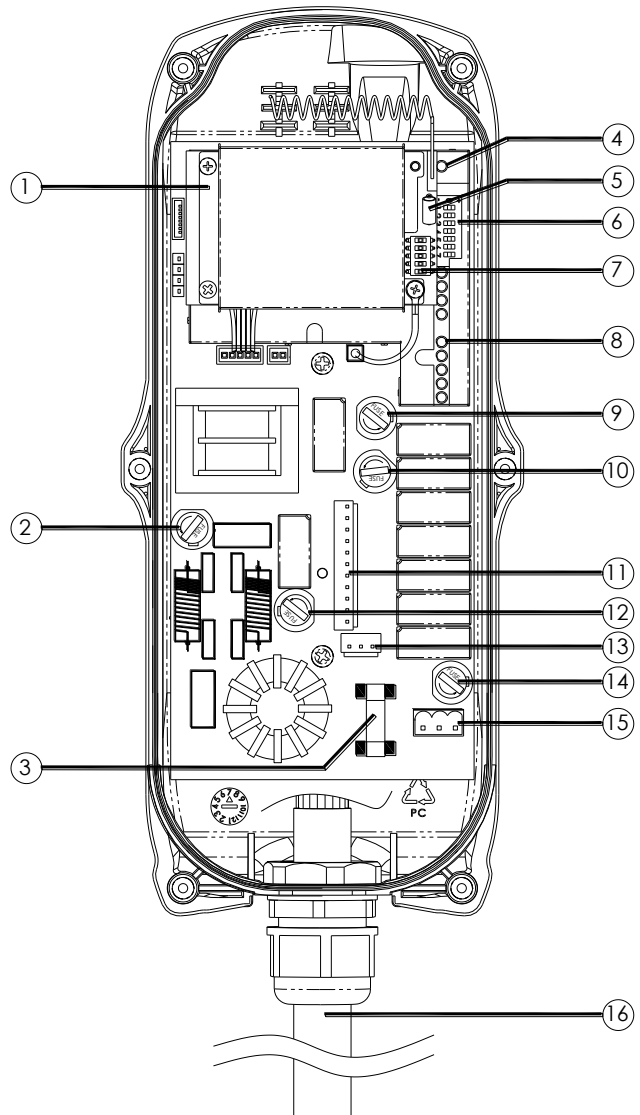

- 1) Spare fuse & jumper compartment
- 2) Spare Jumper slots
- 3) Spare fuse slots
- 4) Receiver top casing

5.3 Alpha 540 & 560 Models Internal Assembly

(Fig. 16) Internal Parts Assembly

- 1) Receiving RF module
- 2) External programming port
- 3) Secondary power AC fuse (0.50A)
- 4) Contact output seat (CN8)
- 5) Primary power AC fuse (1.0A)
- 6) AC power input seat (CN2)
- 7) Internal Antenna
- 8) System Status LED display*
- 9) External antenna port
- 10) ID code dip-switch
- 11) RF channel dip-switch
- 12) Contact relay LED display
- 13) Pushbutton #1 and #2 fuse (5.0A)
- 14) Contact output seat (CN3)
- 15) MAIN contact fuse (5.0A)
- 16) Pushbutton #3 and #4 fuse (5.0A)
- 17) Pushbutton #5 and #6 fuse (5.0A)
- 18) Contact output seat (CN4)
- 19) LV & AUX fuse (5.0A)
- 20) Cable gland & output cable

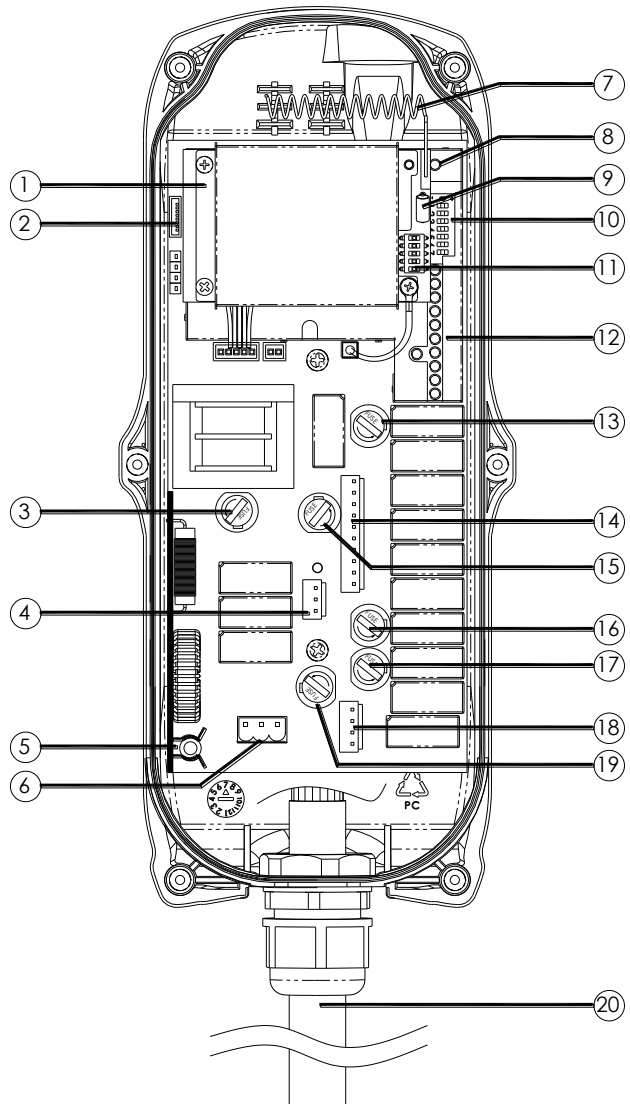

* Please refer to page 32 for system status LED display information.

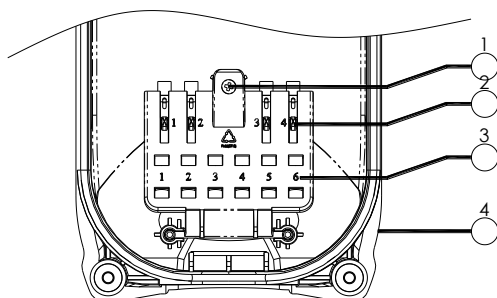

- 1) Spare fuse & jumper compartment
- 2) Spare Jumper slots
- 3) Spare fuse slots
- 4) Receiver top casing

5.4 Alpha 580 Models External Assembly

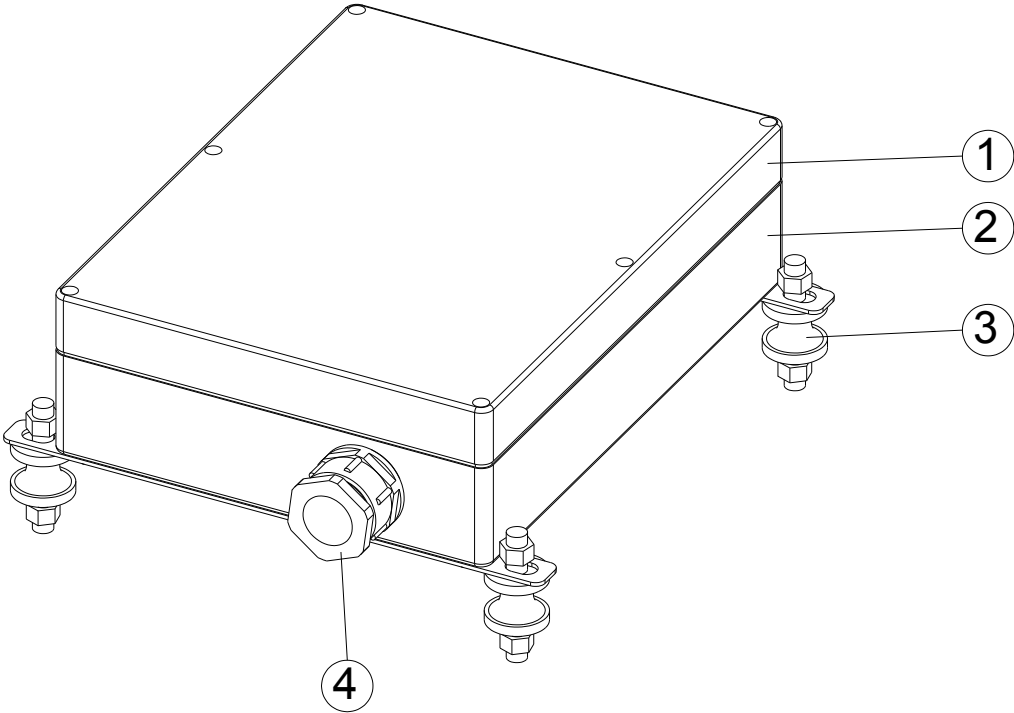

(Fig. 17) External Parts Assembly

- 1) Transparent top cover
- 2) Light-gray colored base
- 3) Mounting bracket with shock absorbers
- 4) Cable gland / Cord grip

5.5 Alpha 580 Models Internal Assembly

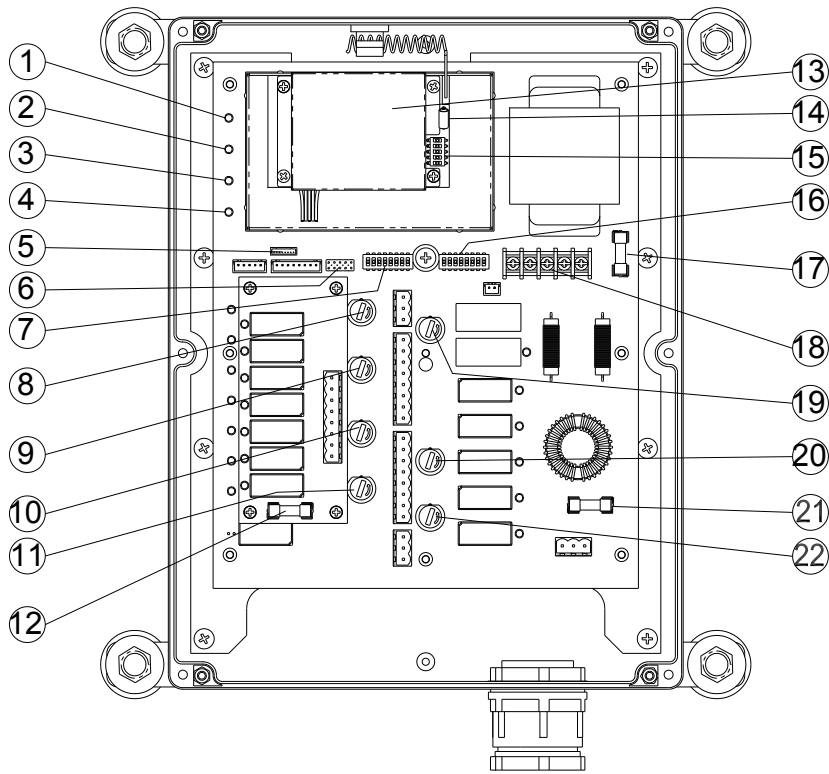

(Fig. 18) Internal Parts Assembly

- | | |
|--|--|
| 1) Power LED display* | 12) Pushbutton #1 and #2 relay fuse (5.0A) |
| 2) SQ LED display** | 13) Receiving RF module |
| 3) Status LED display**** | 14) External antenna port |
| 4) DC power relay LED display*** | 15) RF channel dip-switch |
| 5) Programming port | 16) ID code dip-switch |
| 6) Jumper settings | 17) Secondary power fuse (0.8A) |
| 7) Function dip-switch | 18) Voltage selector seat |
| 8) Pushbutton #3 and #4 relay fuse (5.0A) | 19) MAIN relay fuse (5.0A) |
| 9) Pushbutton #5 and #6 relay fuse (5.0A) | 20) Pushbutton A4 relay fuse (5.0A) |
| 10) Pushbutton A1 and A2 relay fuse (5.0A) | 21) Primary power fuse (1.0A) |
| 11) Pushbutton A3 relay fuse (5.0A) | 22) Low-voltage (LV) relay fuse (5.0A) |

* **POWER** ~ AC Power Source Indicator "on" → AC input power supplied.
"off" → No AC input power.

** **SQ** ~ RF Signal Indicator "on" → RF signal detected and received.
"off" → No RF signal detected or received.

Blinking at transmitter power "off" → Other radio interference.

*** **RELAY_COM** ~ DC Power Source to Relays "on" → DC power to relays.
"off" → No DC power to relays.

**** **STATUS** ~ Receiver System Status LED Display → Please refer to page 32.

6. OUTPUT CONTACT DIAGRAMS

6.1 Alpha 500 & 520 Models

(Alpha 500 v2.1)

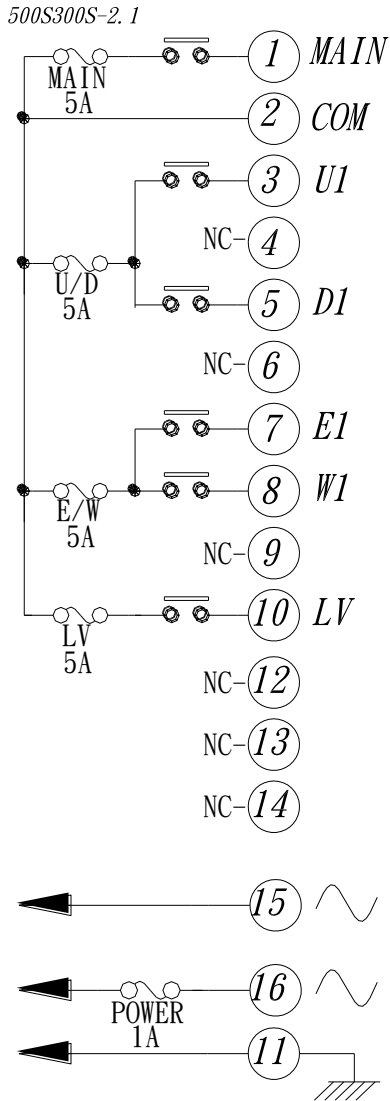

(Alpha 520 v2.1)

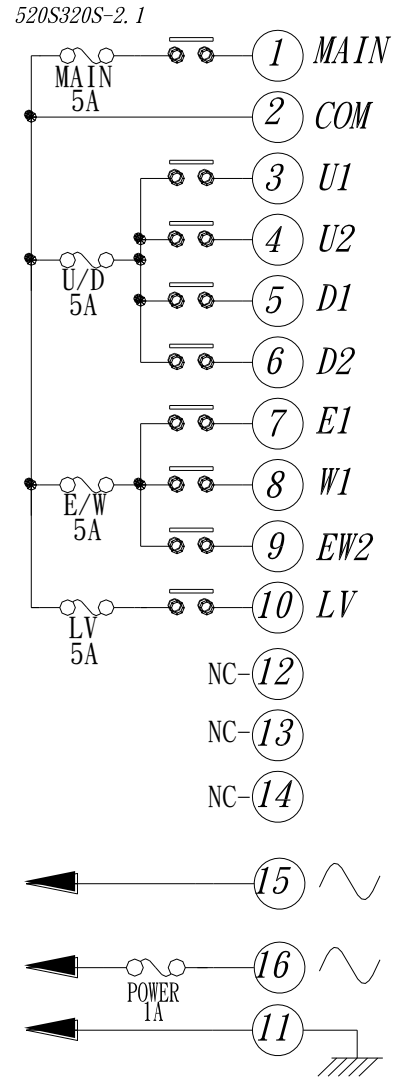

(Alpha 500 v2.2)

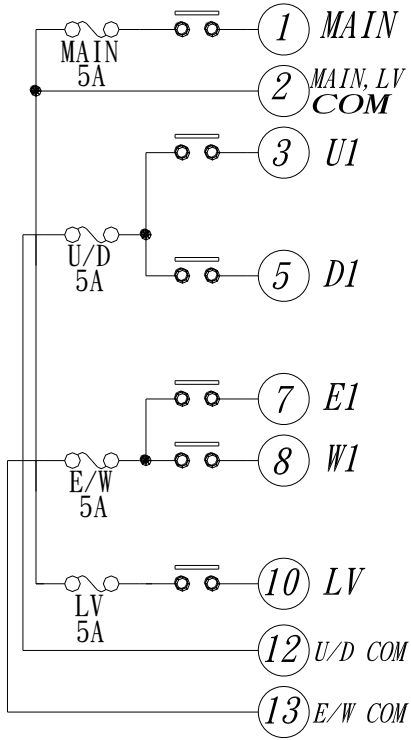

(Alpha 520 v2.2)

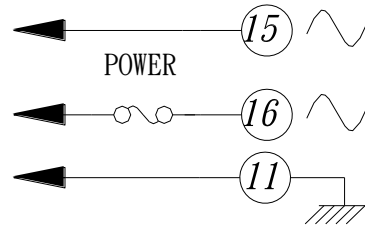
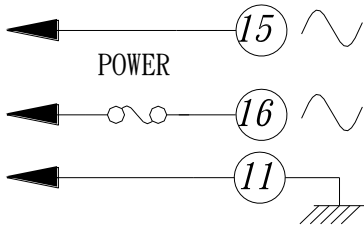
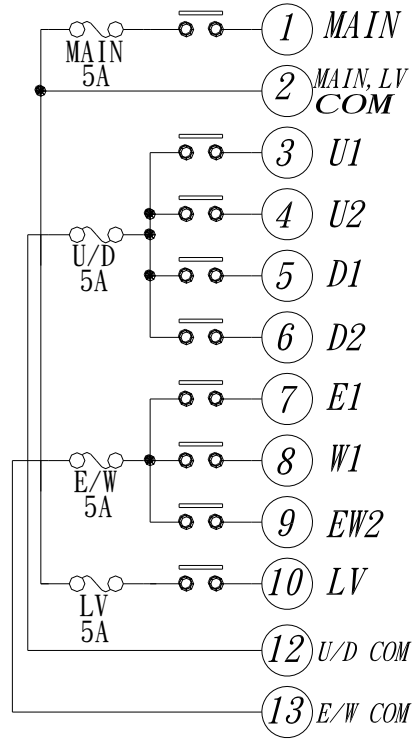

6.2 Alpha 540 Models

(Alpha 540S v4.1)

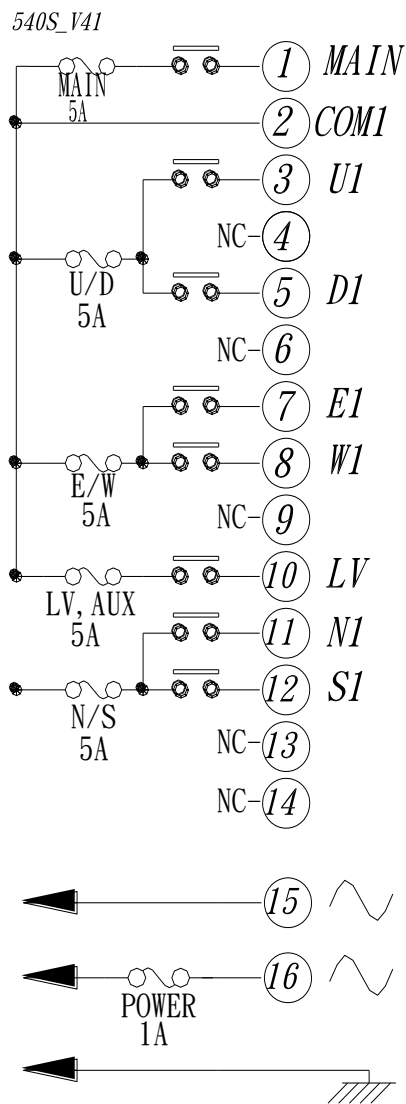

(Alpha 540A v4.1)

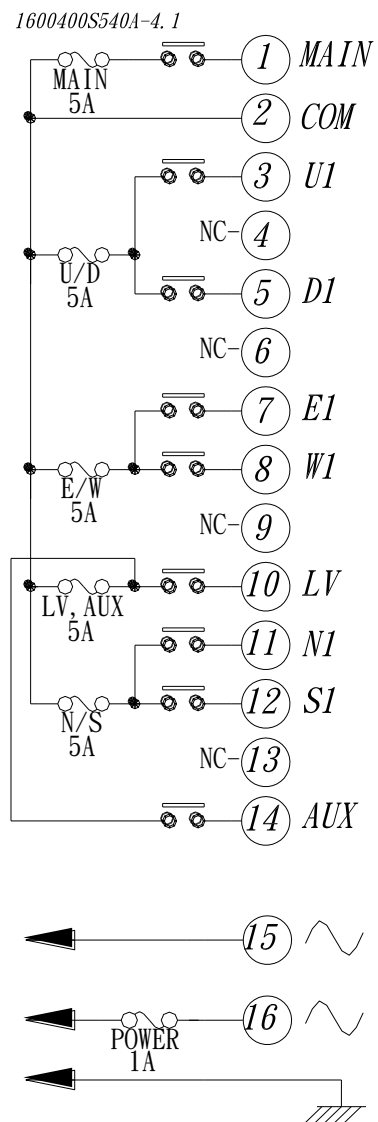

(Alpha 540S v4.2)

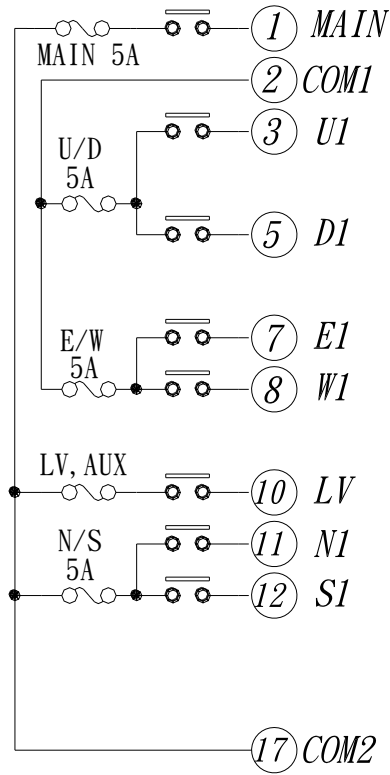

(Alpha 540A v4.2)

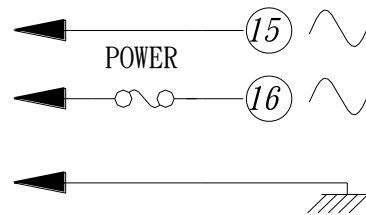
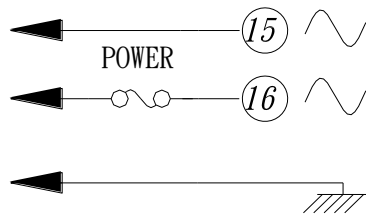
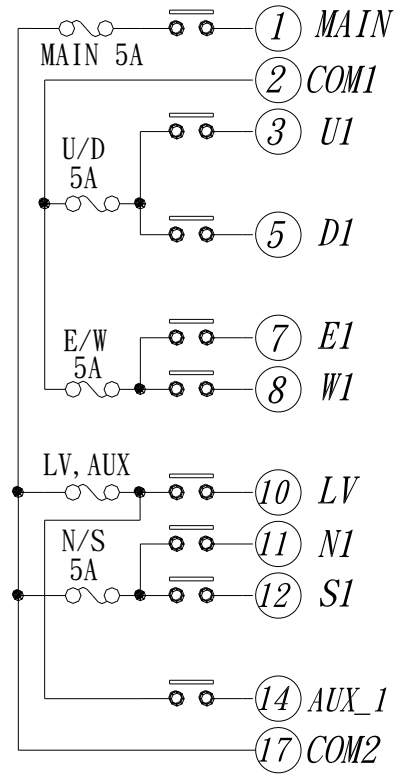

(Alpha 540S v5)

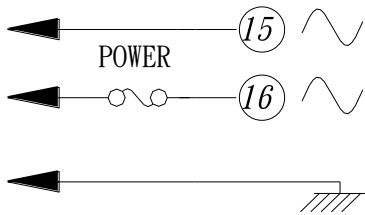
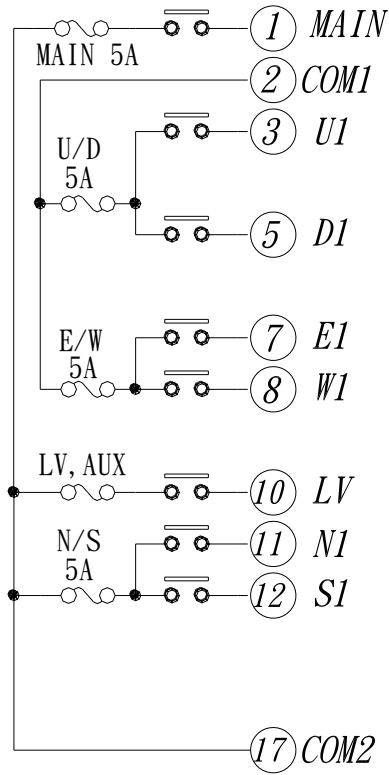

(Alpha 540A v5)

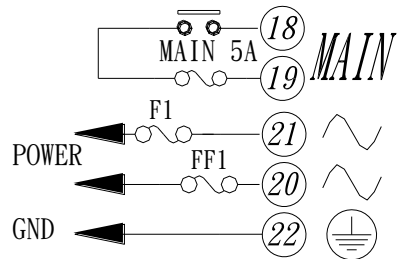
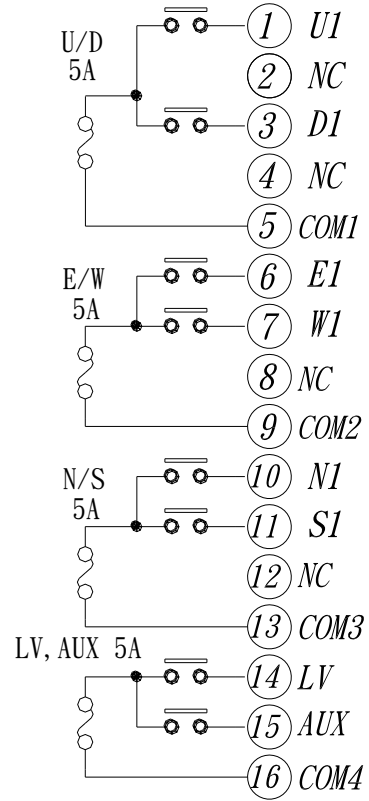

(Alpha 540T)

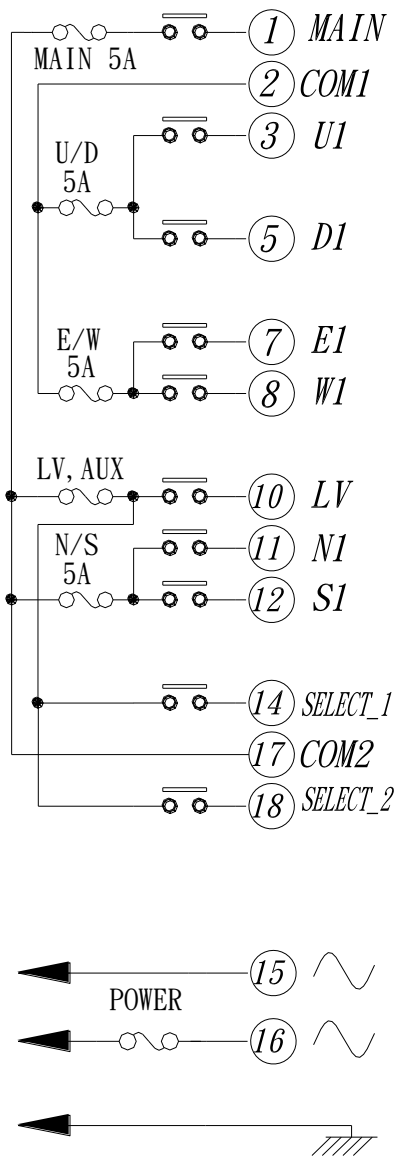

6.3 Alpha 560 Models

(Alpha 560S v4.1)

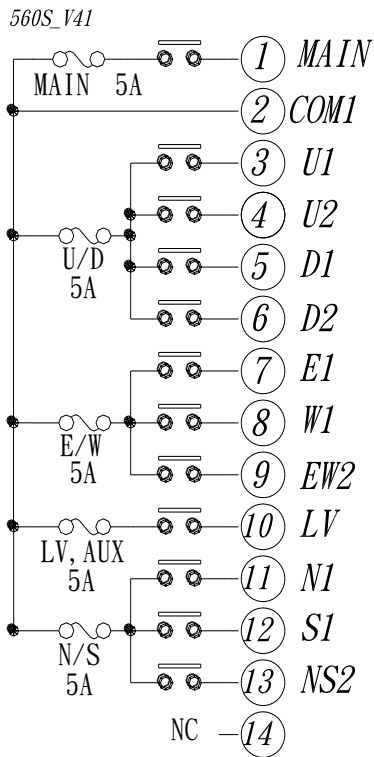

(Alpha 560A v4.1)

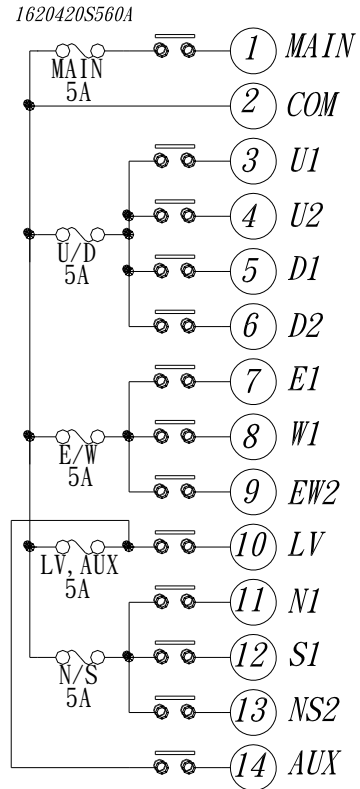

(Alpha 560S v4.2)

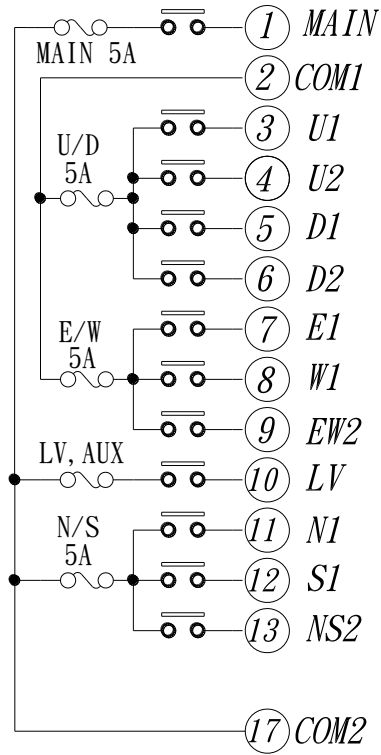

(Alpha 560A v4.2)

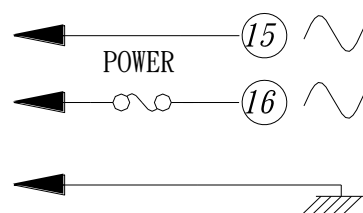
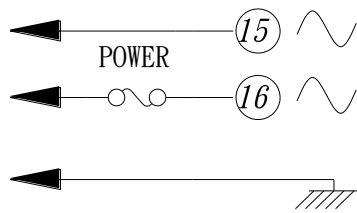
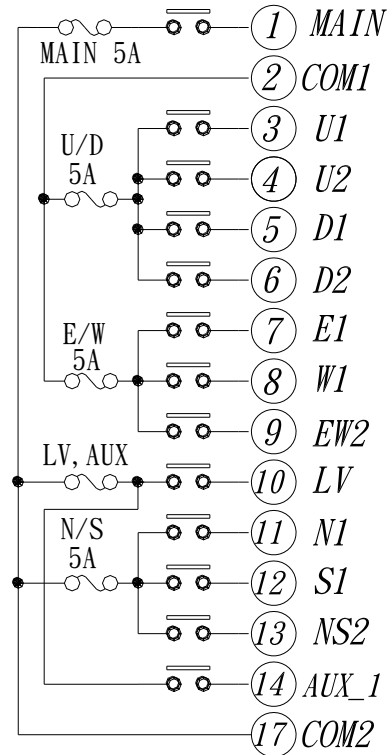

(Alpha 560S v5)

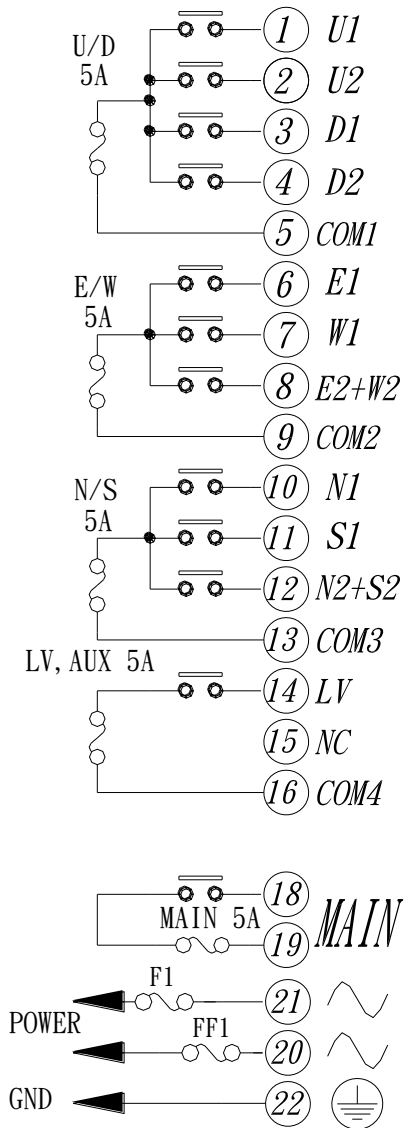

(Alpha 560A v5)

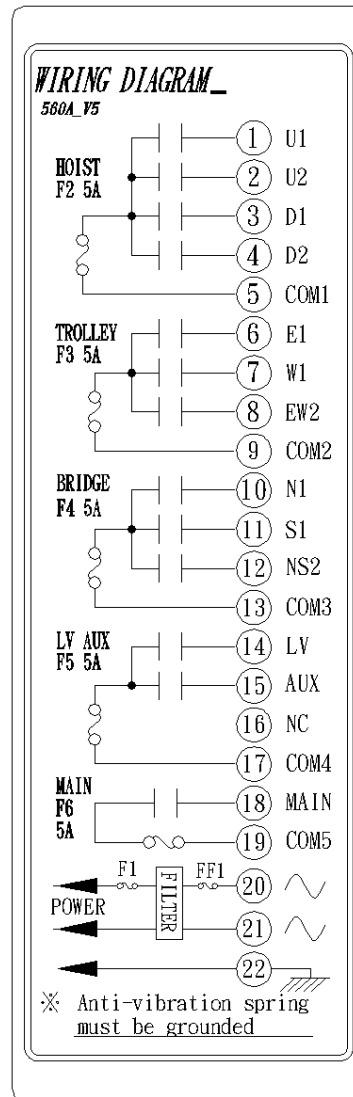

NC → No connection

(Alpha 560T)

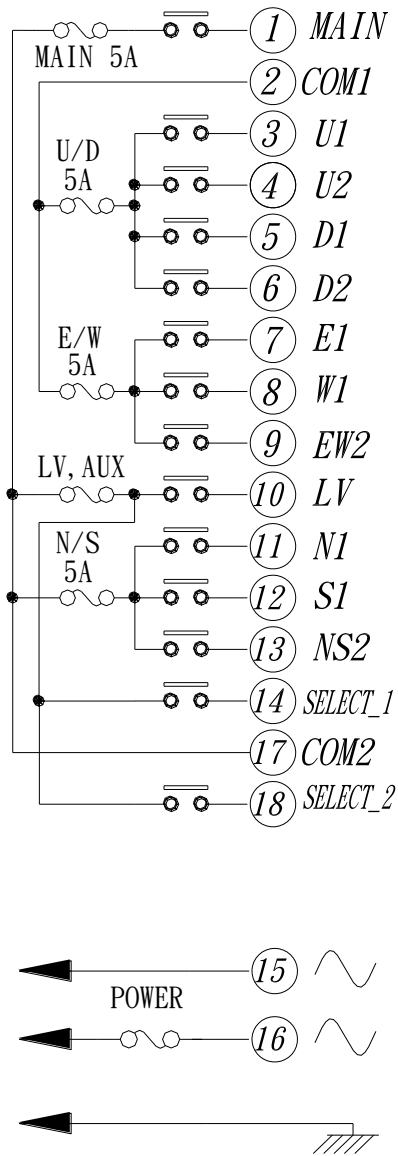

6.4 Alpha 580 Models

(Alpha 580A-1)

&

(Alpha 580A-2)

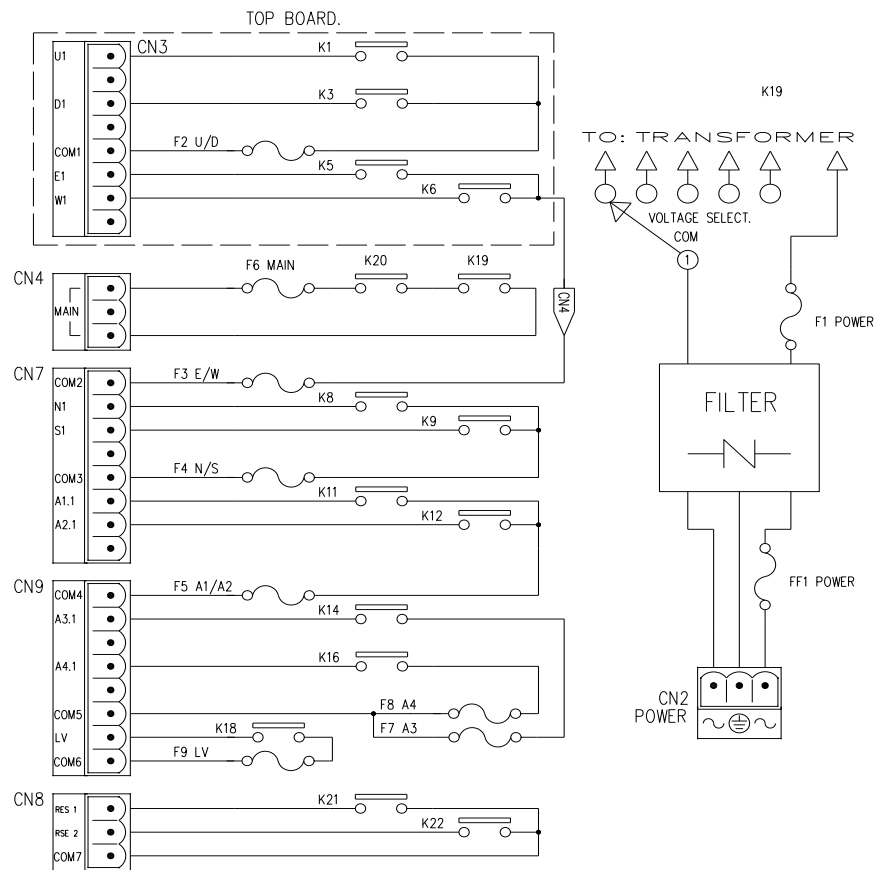

Note: The output contact diagram for both Alpha 580A-1 and Alpha 580A-2 models are identical, the only difference is the transmitter pushbutton labeling.

(Alpha 580B)

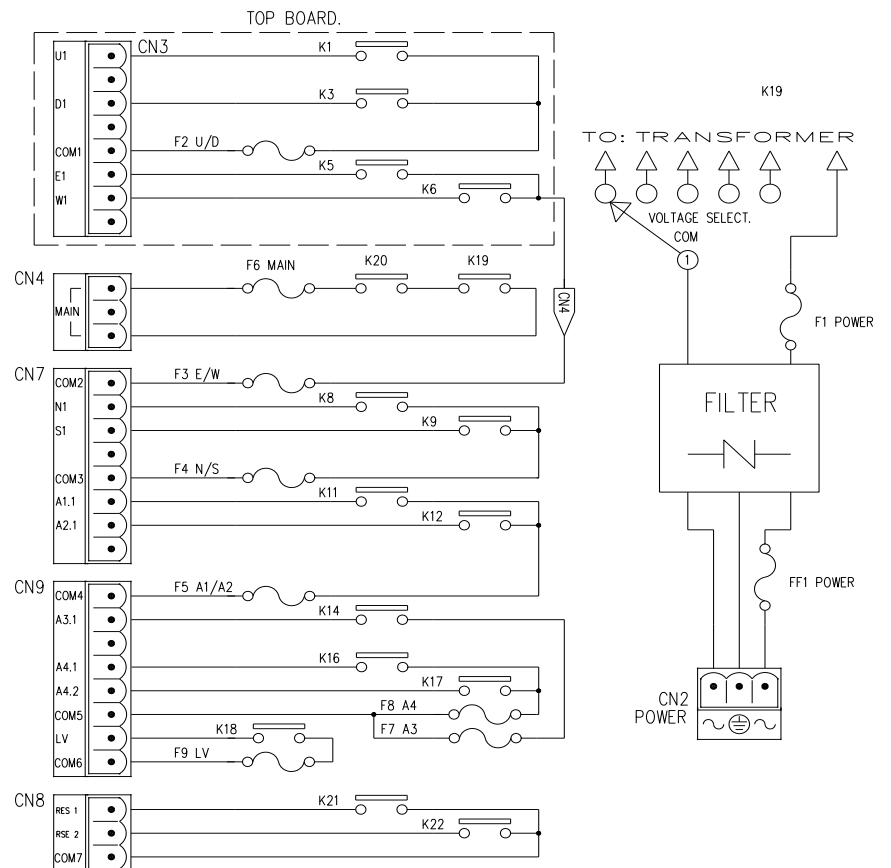

(Alpha 580C-1)
&
(Alpha 580C-2)

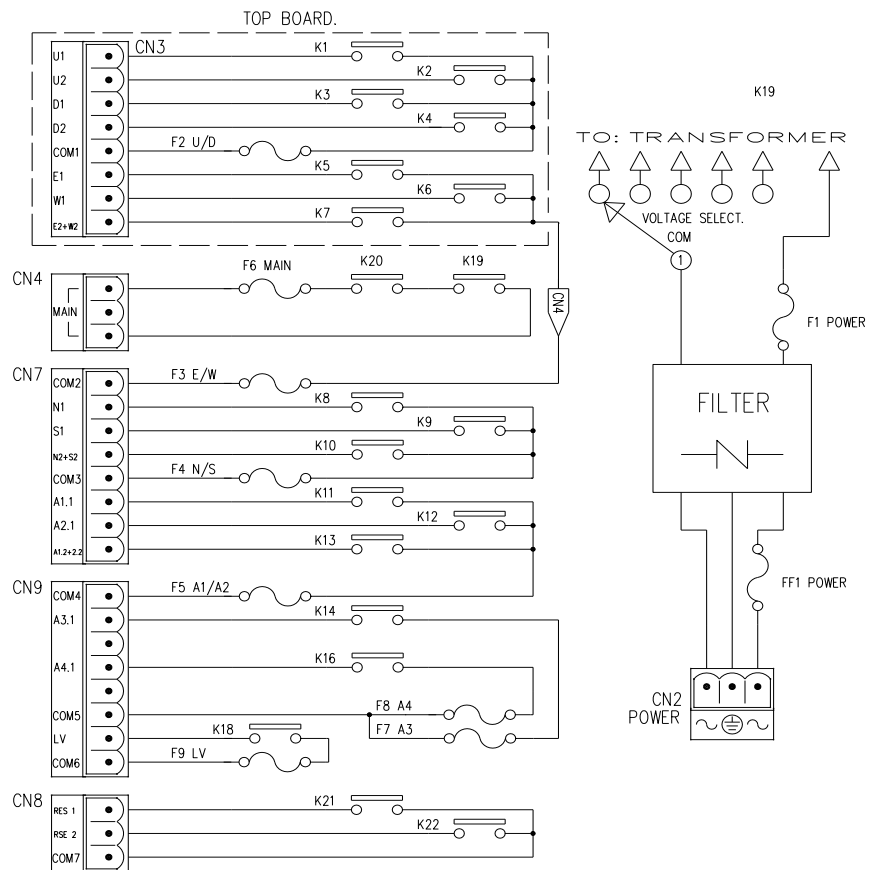

Note: For Alpha 580C-1 model, please disregard "A1.2 + 2.2" terminal output.

(Alpha 580D)

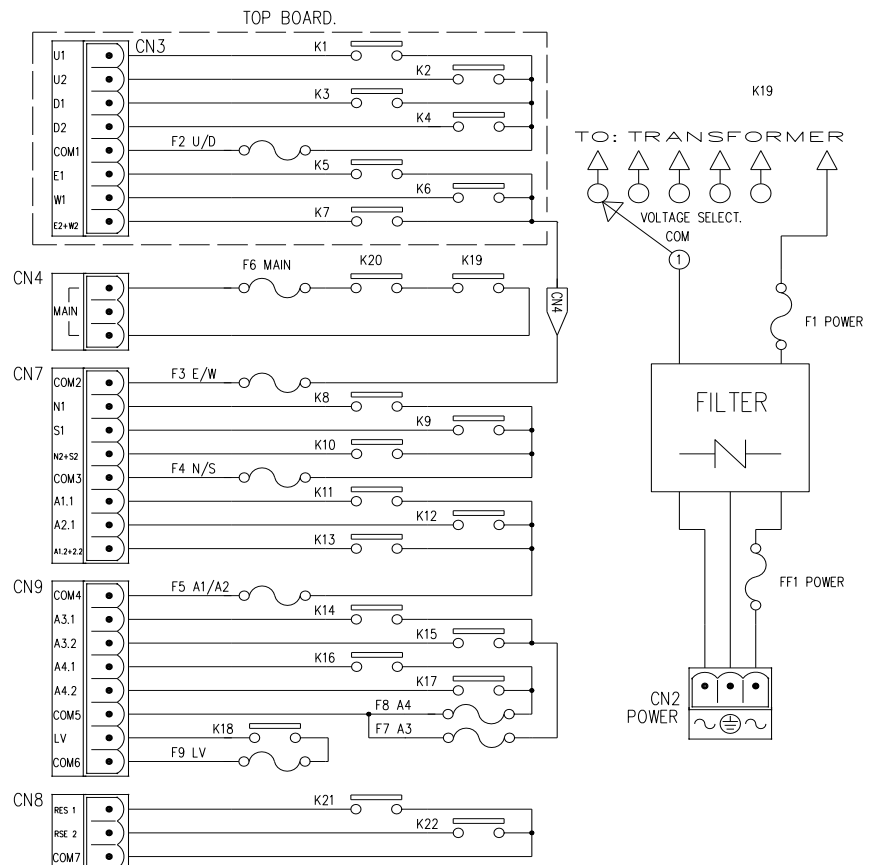

(Alpha 580E)

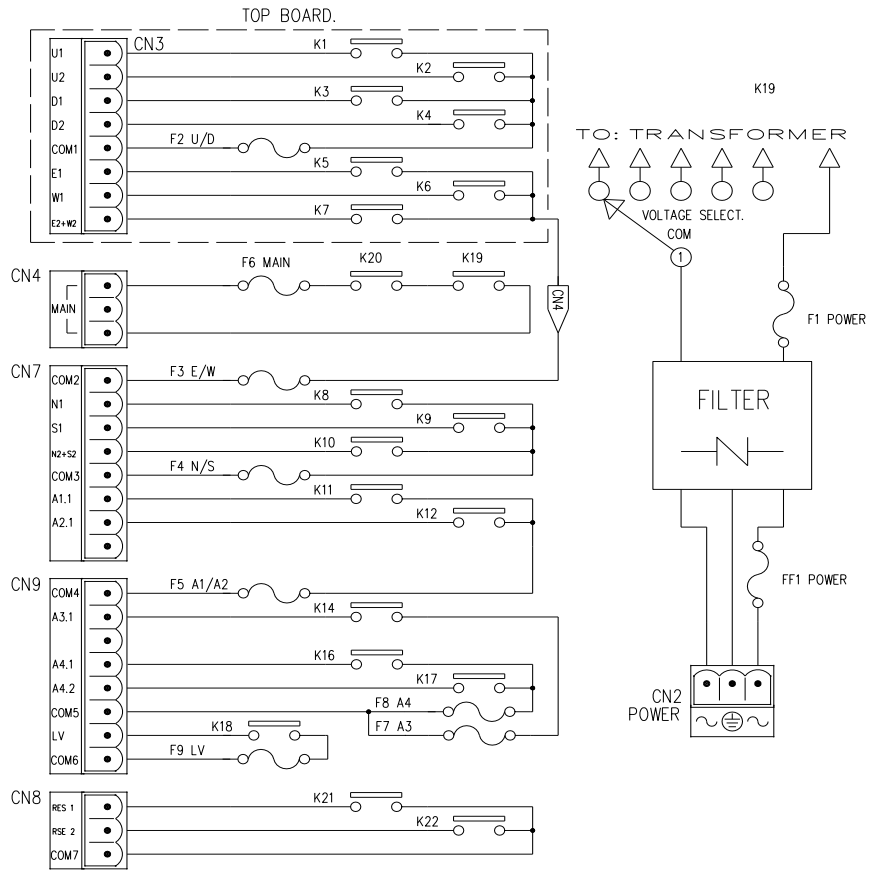

(Alpha 580F)

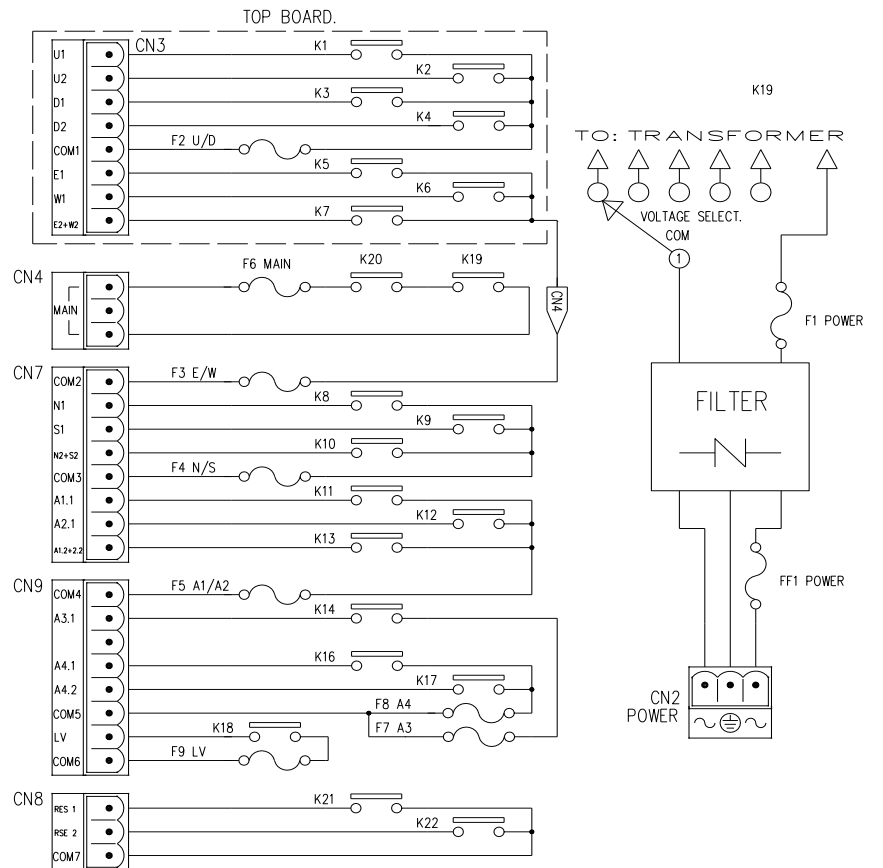

7. SYSTEM CONFIGURATIONS

7.1 How To Set Jumper Functions

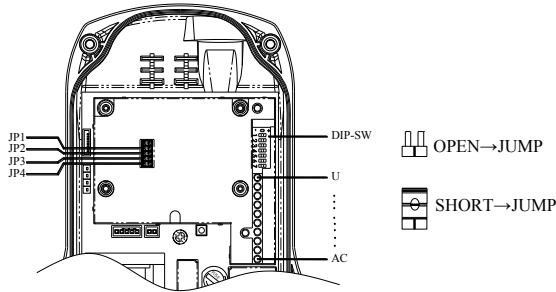

(Fig. 19) Alpha 500 ~ 560 Models

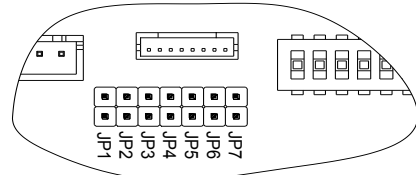

(Fig. 20) Alpha 580 Models

Manufacture Settings

JP1	Open	<p>For Alpha 580 models only</p> <ol style="list-style-type: none"> After turning “on” the transmitter power, press START/AUX pushbutton to activate the receiver MAIN. After EMS Reset, press START/AUX pushbutton to activate the receiver MAIN.
	Short	<p>For all models</p> <ol style="list-style-type: none"> Turning “on” the transmitter power will activate the receiver MAIN. Resetting the EMS will activate the receiver MAIN.
JP2	Open	Reserved
	Short	Reserved
JP3	Open	<p>For all models</p> <p>After 1 minute of transmitter low-voltage warning, the transmitter power will be deactivated.</p>
	Short	<p>For all models</p> <p>After 1 minute of transmitter low-voltage warning, the transmitter power “and” the receiver MAIN will be deactivated. (refer to note A below)</p>
JP4	Open	<p>For Alpha 540A & 560A models</p> <p>AUX button with normal momentary relay contact.</p>
	Short	<p>For Alpha 540A & 560A models</p> <p>AUX button with latching relay contact.</p>

Note A: If transmitter low-voltage condition occurs during operation the transmitter handset itself will display a visual warning by blinking the status light red. Furthermore, the transmitter will also send out a special low-voltage command signal to the receiver to activate its internal low-voltage (LV) warning relay. By connecting a horn, siren or lights to the LV relay output the operator can be notified of a transmitter low-voltage condition. The LV relay will open and close at one-second intervals for up to a minute warning the operator of the low-voltage condition. To insure maximum safety, both the transmitter power and the receiver MAIN will be deactivated (depending on JP3 settings)

Note B: Every time when you change jumper settings you must first turn the receiver power “off” and then turn it back “on” so that the new settings can be stored in memory.

JP-1 Setting (for Alpha 580 models only)

JP1 Open	Power "On"	Press START/AUX pushbutton	Receiver MAIN activated	OR	Reset EMS button	Press START/AUX pushbutton	Receiver MAIN activated
JP4 Short	Power "On"	Receiver MAIN activated		OR	Reset EMS button	Receiver MAIN activated	

JP-3 Setting (for all models)

JP3 Open	Power "On"	Work in progress	Transmitter low-voltage condition occurs	LV warning	Replace batteries within 1 minute	YES	Work resumes
						NO	Transmitter unit will be deactivated
JP3 Short	Power "On"	Work in progress	Transmitter low-voltage condition occurs	LV warning	Replace batteries within 1 minute	YES	Work resumes
						NO	The transmitter power and the receiver MAIN will be deactivated

JP-4 Settings (for Alpha 540A & 560A models only)

JP4 Open	AUX button with normal momentary relay contact
JP4 Short	AUX button with latching/toggled relay contact

7.2 How to Set ID Codes

The ID code dip-switch is located on the backside of the transmitter encoder board and on the top side of the receiver decoder/relay board (refer to section 3~5). When you change the ID code of the system please make sure that the "1" value adds up to be an "Even" number (see below).

Example : ID code → **10010110** → "1" x 4 = 4 → Even number → Correct setting

Top slot → "1"

Bottom slot → "0"

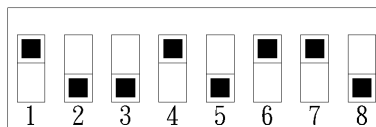

Example : ID code → **10001100** → "1" x 3 = 3 → Odd number → Correct setting

Top slot → "1"

Bottom slot → "0"

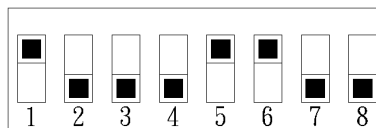

Note:

Depending on area, models in some countries may have "Odd" numbered group ID code. Please check the ID code information located on the backside of the transmitter handset or on the face cover of the receiver unit for correct ID code setting (odd or even).

7.3 Receiver RF Channel Setting

There are 20 sets of user-adjustable receiving RF channels that can be set manually via a 5-position dip-switch located to the right of the receiving RF module. Change the receiving RF channel simply by resetting these 5-position dip-switch. For the location of the receiving RF module, please refer to fig. 15, 16, and 18 on page 11, 12, and 14.

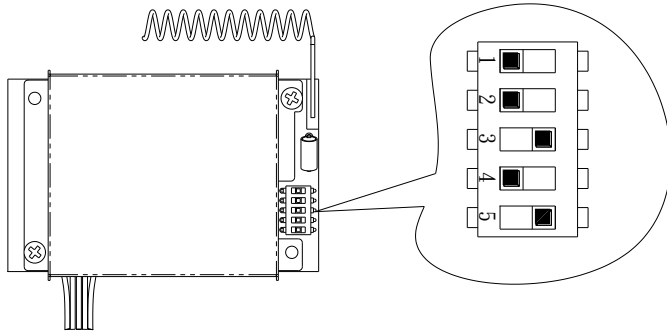

Example: For the above dip setting (**00101**) counting from dip-position #1 through #5, the RF channel would be **“405”**, which also represents frequency **“433.175 MHz”**. Please refer to the frequency (RF) channel table on page 26 or the CHANNEL → DIP label located on the receiving RF module.

7.4 How to Remove the Transmitting RF Board

The transmitter RF channel can be easily replaced or exchanged simply by replacing the small removable RF board located atop the transmitter encoder board. The small RF board can be easily removed by unscrewing the two small bolts that secured the RF board and the encoder board together (refer to the diagram below). Please keep in mind that the RF channel of the transmitter must be identical to the receiver. If the RF channel for both transmitter and receiver are different, please readjust accordingly (refer to section 7.3 above).

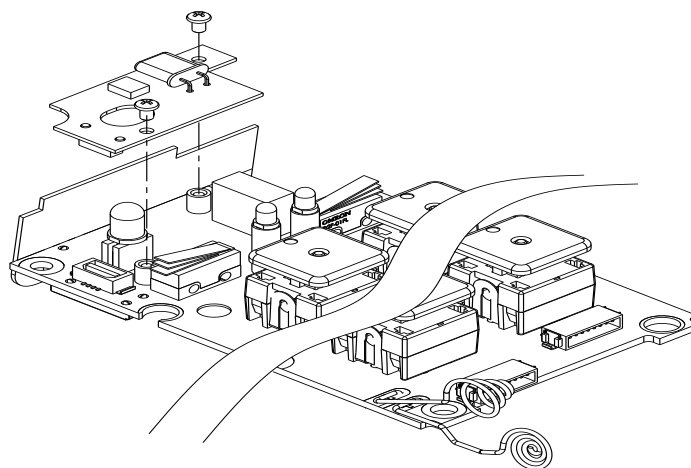

7.5 Alpha 580 Models Pushbutton Function Settings

Numerous Alpha 580 models' pushbutton contact relay settings can be set via an 8-position dip-switch located on the receiver decoder/relay board (refer to fig. 18 on page 14).

Example:

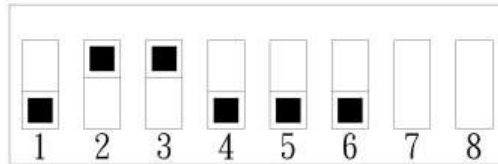

DIP-1 → "0"
 DIP-2 → "1"
 DIP-3 → "1"
 DIP-4 → "0"
 DIP-5 → "0"
 DIP-6 → "0"

Top slot represents "1" value and lower slot represents "0" value.

Alpha 580 models dip-switch function table

<p>Alpha 580A-1 & Alpha 580A-2</p>	<p>DIP1 → "0" → pushbutton 1&2, 3&4, 5&6 interlocked "1" → pushbutton 1&2, 3&4, 5&6 not interlocked</p> <p>DIP2 → "0" → pushbuttons 7&8 interlocked "1" → pushbutton 7&8 not interlocked</p> <p>DIP3 → "0" → pushbutton 7&8 with momentary relay contact (DIP2 set at "1") "1" → pushbutton 7&8 with latching/toggled relay contact (DIP2 set at "1")</p> <p>DIP4 → "0" → pushbutton 9&10 interlocked "1" → pushbutton 9&10 not interlocked</p> <p>DIP5 → "0" → pushbutton 9 with momentary relay contact (DIP4 set at "1") "1" → pushbutton 9 with latching/toggled relay contact (DIP4 set at "1")</p> <p>DIP6 → "0" → 10th pushbutton with momentary relay contact (DIP4 set at "1") "1" → 10th pushbutton with latching/toggled relay contact (DIP4 set at "1")</p>
<p>Alpha 580B</p>	<p>DIP1 → "0" → pushbutton 7&8 interlocked "1" → pushbutton 7&8 not interlocked</p> <p>DIP2 → "0" → pushbuttons 7 with momentary relay contact (DIP1 set at "1") "1" → pushbutton 7 with latching/toggled relay contact (DIP1 set at "1")</p> <p>DIP3 → "0" → pushbutton 8 with momentary relay contact (DIP1 set at "1") "1" → pushbutton 8 with latching/toggled relay contact (DIP1 set at "1")</p> <p>DIP4 → "0" → pushbutton 9 with momentary relay contact "1" → pushbutton 9 with latching/toggled relay contact</p>

Alpha 580 models dip-switch function table (continued)

Alpha 580C-1 & Alpha 580C-2	<p>DIP1 → “0” → pushbutton 1&2 with both 1st and 2nd speed contact relay activated when pressed to 2nd speed (refer to note A) “1” → pushbutton 1&2 with both 1st and 2nd speed contact relay interlocked when pressed to 2nd speed (refer to note B)</p> <p>DIP2&3 → “00” → pushbuttons 9 with momentary relay contact “01” → pushbutton 9 with latching/toggled relay contact “10” → pushbutton 9 with 3rd speed function (refer to note C)</p> <p>DIP4 → “0” → pushbutton 10 with momentary relay contact “1” → pushbutton 10 with latching/toggled relay contact</p>
Alpha 580D	<p>DIP1 → “0” → pushbutton 1&2 with both 1st and 2nd speed contact relay activated when pressed to 2nd speed (refer to note A) “1” → pushbutton 1&2 with both 1st and 2nd speed contact relay interlocked when pressed to 2nd speed (refer to note B)</p> <p>DIP2 & DIP3 must set to “0” at all time</p>
Alpha 580E	<p>DIP1 → “0” → pushbutton 1&2 with both 1st and 2nd speed contact relay activated when pressed to 2nd speed (refer to note A) “1” → pushbutton 1&2 with both 1st and 2nd speed contact relay interlocked when pressed to 2nd speed (refer to note B)</p> <p>DIP2 → “0” → pushbuttons 7&8 interlocked “1” → pushbutton 7&8 not interlocked</p> <p>DIP3 → “0” → pushbutton 7 with momentary relay contact (DIP2 set at “1”) “1” → pushbutton 7 with latching/toggled relay contact (DIP2 set at “1”)</p> <p>DIP4 → “0” → pushbutton 8 with momentary relay contact (DIP2 set at “1”) “1” → pushbutton 8 with latching/toggled relay contact (DIP2 set at “1”)</p> <p>DIP5&6 → “00” → pushbutton 9 with momentary relay contact “01” → pushbutton 9 with latching/toggled relay contact “10” → pushbutton 9 with 3rd speed function (refer to note C)</p>
Alpha 580F	<p>DIP1 → “0” → pushbutton 1&2 with both 1st and 2nd speed contact relay activated when pressed to 2nd speed (refer to note A) “1” → pushbutton 1&2 with both 1st and 2nd speed contact relay interlocked when pressed to 2nd speed (refer to note B)</p> <p>DIP2&3 → “00” → pushbutton 9 with momentary relay contact “01” → pushbutton 9 with latching/toggled relay contact “10” → pushbutton 9 with 3rd speed function (refer to note C)</p>

Note A: This setting is ideal for majority of the crane systems (manufacture preset). When pressed to 2nd speed for the hoist motion, the 1st speed contact relay will remain engaged (closed) along with the 2nd speed contact relay.

Note B: This setting is ideal for crane system with dual-motor hoist. When pressed to 2nd speed for the hoist motion, the 1st speed contact relay will be disengaged (open), with only the 2nd speed contact relay engaged (closed).

Note C: During operation, when a particular command pushbutton is in the 2nd speed position (pushbutton fully pressed), pressing the 10th pushbutton once will activate the 3rd speed contact relay. If the operator presses the 10th pushbutton again, the command pushbutton currently in use will return to the 2nd speed position.

7.6 Frequency (RF) Channels Table

FREQUENCY	DIP-SWITCH SETTING	RF CHANNEL
301.105 MHz	00001	201
301.130 MHz	00010	202
301.155 MHz	00011	203
301.180 MHz	00100	204
301.205 MHz	00101	205
301.230 MHz	00110	206
301.255 MHz	00111	207
301.280 MHz	01000	208
301.305 MHz	01001	209
301.330 MHz	01010	210
301.355 MHz	01011	211
301.380 MHz	01100	212
301.405 MHz	01101	213
301.430 MHz	01110	214
301.455 MHz	01111	215
301.480 MHz	10000	216
301.505 MHz	10001	217
301.530 MHz	10010	218
301.555 MHz	10011	219
301.580 MHz	10100	220
301.605 MHz	10101	221
301.630 MHz	10110	222
301.655 MHz	10111	223
301.680 MHz	11000	224
301.705 MHz	11001	225
301.730 MHz	11010	226
301.755 MHz	11011	227
301.780 MHz	11100	228
301.805 MHz	11101	229
301.830 MHz	11110	230

FREQUENCY	DIP-SWITCH SETTING	CHANNEL
433.075 MHz	00001	401
433.100 MHz	00010	402
433.125 MHz	00011	403
433.150 MHz	00100	404
433.175 MHz	00101	405
433.200 MHz	00110	406
433.225 MHz	00111	407
433.250 MHz	01000	408
433.275 MHz	01001	409
433.300 MHz	01010	410
433.825 MHz	01011	411
433.850 MHz	01100	412
433.875 MHz	01101	413
433.900 MHz	01110	414
433.925 MHz	01111	415
433.950 MHz	10000	416
433.975 MHz	10001	417
434.000 MHz	10010	418
434.025 MHz	10011	419
434.050 MHz	10100	420
434.075 MHz	10101	421
434.100 MHz	10110	422
434.125 MHz	10111	423
434.150 MHz	11000	424
434.175 MHz	11001	425
434.200 MHz	11010	426
434.225 MHz	11011	427
434.250 MHz	11100	428
434.275 MHz	11101	429
434.300 MHz	11110	430

FREQUENCY	DIP-SWITCH SETTING	CHANNEL
447.8750 MHz	00001	701
447.8875MHz	00010	702
447.9000MHz	00011	703
447.9125MHz	00100	704
447.9250MHz	00101	705
447.9375MHz	00110	706
447.9500MHz	00111	707
447.9625MHz	01000	708
447.9750 MHz	01001	709
447.9875MHz	01010	710

8. RECEIVER INSTALLATION

8.1 Preparation For Installation

1. Required Tools for Receiver Installation:
 - (1) Flat Head Screwdriver (-)
 - (2) Phillips Head Screwdriver (+)
 - (3) Multi-Meter
 - (4) 14mm Wrench x 2
 - (5) Power Drill with 10.5mm Drill-Bit
2. Check to ensure that your receiver is not set to the same RF channel and ID code as any other systems in operation at the same facility or within 300-meter distance.
3. Prior to installation, make sure that the crane or equipment itself is working properly.
4. Use a multi-meter to check the voltage source available and ensure the receiver voltage setting matches your power source.
5. Prior to installation, switch off the main power source to the crane or equipment.

8.2 Step By Step Installation

1. For better reception, the location selected should have the antenna visible from all areas where the transmitter is to be used.
2. The location selected should not be exposed to high levels of electrical noise. Mounting the receiver next to an unshielded variable frequency control (inverter) may cause minor interference. Always locate the receiver unit as far away from inverter controls as possible.
3. Ensure the selected location has adequate space to accommodate the receiver enclosure.
4. Make sure the receiver unit is in upright position (vertical).
5. The distance between the antenna and the control panel should be as far apart as possible (refer to fig. 21 and fig. 22 on page 28).
6. If a crane or equipment's runway is longer than 100 meters, an external antenna should be added. The Alpha 500 series' receiver housing has provisions for an external factory installed antenna available as an option, contact your dealer for price and delivery.
7. Alpha 500 ~ 560 models: Drill a hole on the control panel (10.5mm).
Alpha 580 models: Drill 4 holes on the control panel (10.5mm).
8. Tightened the bolt nuts provided.
9. **If the control panel has a plastic surface, extended grounding wire should be used.**
10. For system wiring, please refer to the output contact diagrams from page 15~20.
11. Ensure all wiring is correct and safely secured and all screws are fastened.

The distance between receiver antenna and the control panel should be as far apart as possible.

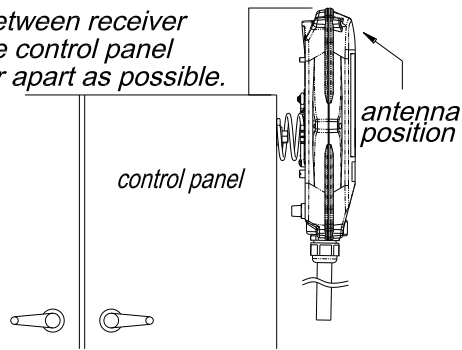

(Fig. 21) Alpha 500 ~ 560 Models

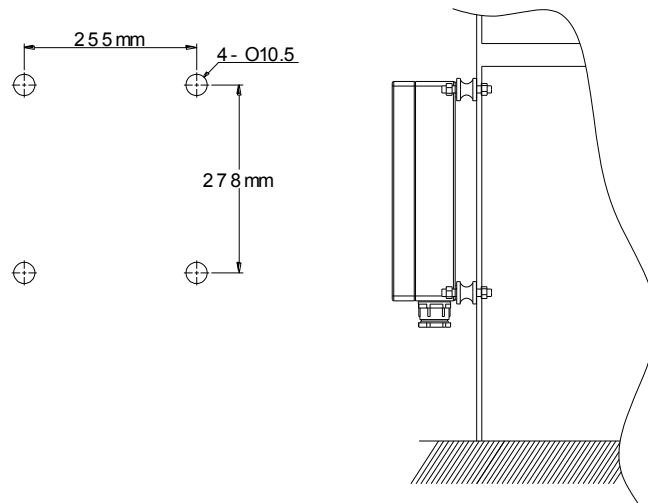

(Fig. 22) Alpha 580 Models

8.3 System Testing

1. Connect the power source to the receiver and test the MAIN relay output by pressing the red emergency stop button (EMS) and observe that it properly opens and closes the main line disconnect contactor.
2. Test the operation of each function to ensure it corresponds to the transmitter direction labels and/or the pendant it is replacing.
3. Test the limit switches on the hoist and/or crane and verify they are working properly.
4. If your new remote control is replacing an existing pendant, make sure it is completely disconnected to prevent unwanted control commands, i. e. snick circuits.
5. If your new remote control is replacing an existing pendant make sure it is stored in a safe location where it will not interfere with remote operation (get torn off).

9. TRANSMITTER OPERATION

1. **Batteries** _ Make sure the two “AA” alkaline batteries are installed correctly. Use 2000mA rated alkaline-type batteries for optimum operating time between replacements. If rechargeable-type batteries are used, for optimum operating time, choose ones rated above 1600mA.
2. **Startup Procedure** _ There are two types of transmitter power key-switch available for the Alpha 500 series, the standard fixed type (refer to fig. 23) and the optional removable type (refer to fig. 24). Basically both key types operate in the same fashion depending on personal preference and safety regulations. For the below illustrations the optional removable-type power key is used.

MODE 0 :

You must first make sure that the red EMS button is elevated prior to turning “on” the transmitter power key-switch, by twisting it 1/4 turn clockwise, it will pop up. Then insert the transmitter power key on to the key-switch slot located on the top left-hand corner of the transmitter handset (refer to fig. 25). To turn “on” the transmitter power, just rotate the power key clockwise to “ON” position. The Status LED located at the center of the key-switch slot will display a constant green light for up to 2 seconds when the power key is inserted and turned to “ON” position. Again, make sure the red EMS button is elevated prior to turning on the transmitter power. If the power key is turned “on” prior to elevating the red EMS button, the transmitter will be locked due to incorrect startup sequence. If this situation occurs, you must reenact the startup procedure, that is, elevate the red EMS button first then turn the power key “off” and then back “on” again.

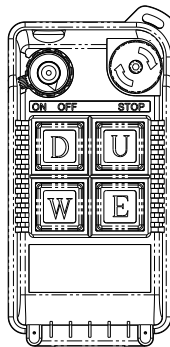

(Fig. 23) Fixed On/Off key

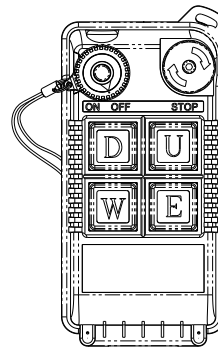

(Fig. 24) Removable On/Off key

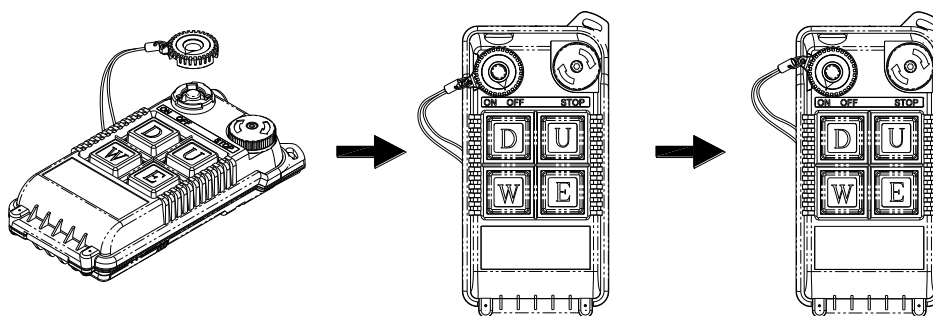

(Fig. 25) Removable On/Off key installation procedure

MODE 1 :

Elevate the red EMS button by twisting it 1/4 turn clockwise; it will pop up. Then insert the transmitter power key onto the key-switch slot located on the top left-hand corner of transmitter handset (refer to fig. 25). Make sure the black arrow marking on the power key is pointed directly towards the "OFF" marking on the transmitter handset. To turn on the transmitter power, just rotate the power key clockwise to "ON" position. The Status LED located at the center of the power switch will display a green blinking light for up to 40 seconds when the power key is turned to "ON" position. At this time the receiver MAIN relay is also activated. After 40 seconds of inactivity, that is 40 seconds after the last pushbutton is released, the green light will disappear thus temporarily deactivating the transmitter power and the receiver MAIN. Pressing any pushbutton thereafter will close the receiver MAIN and start the timing sequence over again. This important safety feature is designed to ensure that the transmitter handset and the receiver MAIN will be in "power off" position if the operator forgets to turn off the transmitter power, or if the transmitter unit is left unattended in the work area.

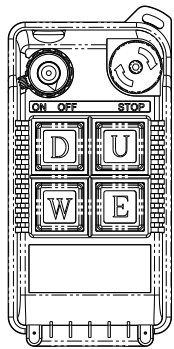

(Fig. 23) Fixed On/Off key

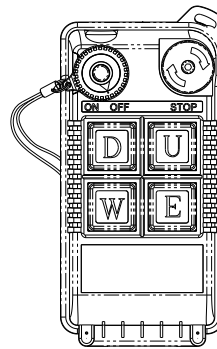

(Fig. 24) Removable On/Off key

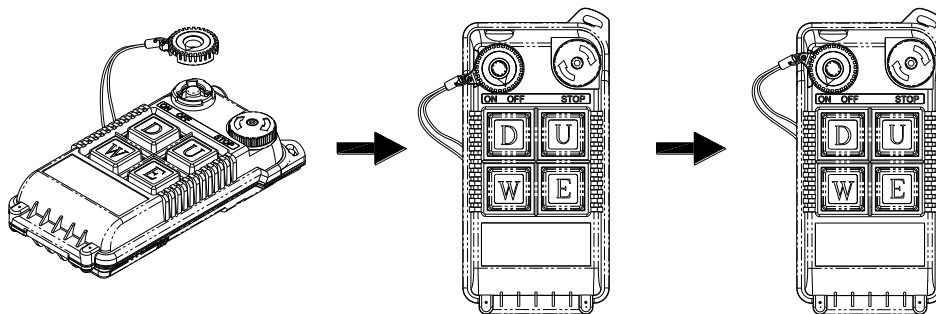

(Fig. 25) Removable power key installation procedure

3. **Status Lights** _ If the transmitter Status LED displays a red blinking light that is “on” → 0.1 second and “off” → 2.0 seconds, or no light at all, this indicates that the two “AA” batteries in the transmitter must be replaced. For battery replacement please refer to instruction next page.

If the transmitter Status LED is blinking red, “on” → 2.0 seconds and “off” → 0.1 second, it means that the transmitter handset is locked due to a damaged or closed pushbutton contact. Also possibly the operator is pressing a pushbutton while going through the start up sequence. This important safety feature is designed to prevent any unexpected crane movement at system startup caused by closed or defective pushbutton contacts.

If the transmitter Status LED displays a constant red light without flashing, this indicates that the transmitter ID code is set incorrectly (refer to section 7.2 on page 22).

4. **EMS & Restarting** _ In case of an emergency, press down the red emergency stop button (EMS) will immediately deactivates the transmitter and receiver MAIN relay. To reactivate the system, just turn the EMS button clockwise 1/4 turn so that the red button pops up (refer to fig. 26 below).

(Fig. 26) EMS Button

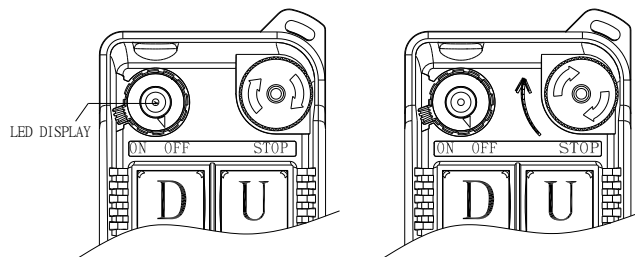

5. **Shutting Off the Transmitter** _ To disconnect the transmitter power and the receiver MAIN relay, just turn the transmitter power to “OFF” position. When the transmitter power is turned off, the receiver MAIN is also deactivated (open).
6. **Models with 3-Stage SELECT Function** _ When the transmitter power key is turned “on”, LED-I will light up indicating only the main hoist and/or trolley is activated. To activate the auxiliary hoist and/or trolley, just press the "Select" pushbutton one time, the LED display will switch from LED-I to LED-II, indicating only the auxiliary hoist and/or trolley is activated. Press the "Select" pushbutton again to have both main and auxiliary hoist and/or trolley activated at the same time (both LED-I and LED-II lit). When both LED-I and LED-II are lit, pressing any pushbutton will result in duplicate movement for the main and auxiliary hoist and/or trolley.

Example: Both main and auxiliary hoist will go up at the same time when “UP” (↑) pushbutton is pressed.

To switch back to the main hoist and/or trolley, just press the "Select" pushbutton again. Please note that every time when the transmitter power is turned “off” and then back “on” again, or after EMS reset, the "Select " setting will default back to LED-I with main hoist and/or trolley active.

- 1) Power "on" → LED-I "lit" → Main hoist and/or trolley activated.
- 2) Press "Select" button once → LED-II "lit" → Auxiliary hoist and/or trolley activated.
- 3) Press "Select" button again → both LED-I & II "lit" → Both main and auxiliary hoist and/or trolley activated with duplicate movements.
- 4) Press "Select" button again → "Select" mode returned to LED-I with only the main hoist and/or trolley activated.

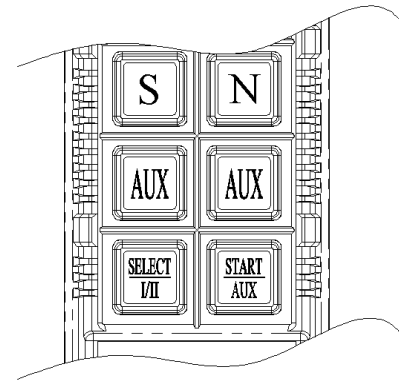

7. **Interlocking Pushbuttons** _ Each set of motion is interlocked to its self so no conflicting commands can take place. For example, pressing the hoist UP (↑) and DOWN (↓) button simultaneously will result in no command signal being sent.
8. **Battery Changing** _ To change batteries, just unscrew the battery cover located on the backside of the transmitter handset with a (+) screwdriver. When changing new batteries, make sure that the batteries are installed correctly. The marking inside the battery compartment will tell you which side is positive (+) charge and which side is negative (-). After changing the batteries, make sure all screws are tightened.

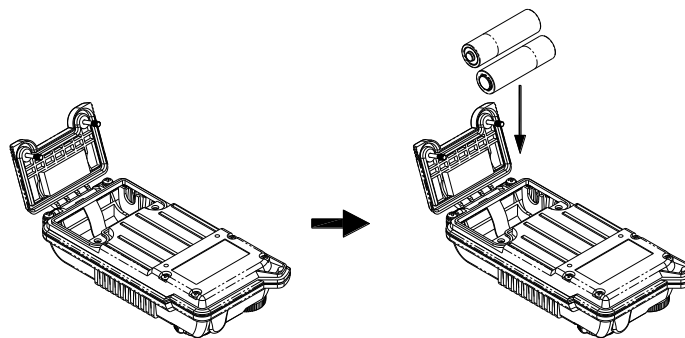

9. **Transmission Data** _ The data of the Alpha 500 series are carried out by the power-saving PCDT method of transmission (Pause Continuous Data Transmission). The duration of each PCDT transmission is set at 40 seconds, with option for 3 minutes (please contact your dealer for more details). During this 40-second PCDT transmission, the transmitter unit will only send out "zero position command" to the receiver if the operator gives no active commands (pushbutton not pressed). If no active commands are given after 40 seconds, that is 40 seconds after the last pushbutton is released, the receiver MAIN will be temporarily deactivated (open). The receiver MAIN can only be reactivated when the receiver unit receives an active command from the transmitter unit by pressing the pushbuttons. Furthermore, if the system encountered strong radio interference or if the transmitter is out of the receiving range during operation, to insure operating safety, the receiver MAIN relay will also be temporarily deactivated.

10. TROUBLE SHOOTING

Should the operator find the equipment not operating normally, please check the chart below for simple trouble shooting tips.

PROBLEM	POSSIBLE REASON	SOLUTION
Transmitter does not communicate with the receiver.	Transmitter and the receiver are not on the same RF channel (SQ lamp not lit) or ID code.	Ensure the correct transmitter is in use. The labels on the receiver and the transmitter will identify the RF channel and ID code in use.
Transmitter does not communicate with the receiver.	Low or no transmitting power from the transmitter unit.	Turn “on” the transmitter with EMS elevated. If the status LED shows blinking red light or no light at all, then turn the power “off” and replace the two alkaline “AA” batteries.
No power to the receiver (AC power indicator on the receiver unit not lit).	Blown fuse or no input power connection.	Ensure power input to the receiver unit is correct. If the power indicator (AC) is still not lit, please check the receiver for any open fuse.
Outputs do not operate correctly.	Receiver configuration is not set properly or output wiring is incorrect.	Please refer to section 6 and 7 to ensure receiver is correctly wired and configured for your application.
Transmitter does not communicate with the receiver.	Transmitter is turned on with the EMS activated (pressed down).	Elevate the EMS first and then turn the power switch off and then on again.

Receiver System Status LED Display

(Refer to fig.15/16/18 on page 11/12/14)

TYPE	LED INDICATION	PROBLEM AND SOLUTION
1	Constant red light.	EEPROM error – reprogramming required.
		Incorrect receiver ID code setting (see note below).
2	ON → 1.0 second OFF → 1.0 second	ID code not matched on both the transmitter and receiver unit, please readjust accordingly.
3	Dim or no light.	Under-voltage, check the main power-supply.
4	ON → 2.0 seconds OFF → 0.1 second	MAIN contact relay jammed or defective.
5	Green ON → 0.1 second OFF → 2.0 seconds	System normal with transmitter power in “on” position and pushbutton is not depressed.
6	ON → 0.1 second OFF → 0.1second	System normal with transmitter pushbutton in non-neutral position (pushbutton depressed).

Note: Please refer to section 7.2 on page 22 for correct ID code setting.

11. SYSTEM SPECIFICATION

Transmitter Unit

Frequency Range	:	433 MHz
Transmitting Range	:	100 meters
Hamming Distance	:	6
Channel Spacing	:	25KHz
Frequency Control	:	Quartz Crystals
Frequency Drift	:	< 5ppm @ -10°C ~ +70°C
Frequency Deviation	:	< 1ppm @ 25°C
Spurious Emission	:	- 50dB
Transmitting Power	:	~1mW
Emission	:	F1D
Antenna Impedance	:	50 ohms
Enclosure Rating	:	IP-66
Source Voltage	:	3.0V ("AA" alkaline batteries x 2)
Current Drain	:	10 ~ 18mA
Operating Temperature	:	-10°C ~ +70°C
Dimension (500~520 Models)	:	140mm x 68mm x 33mm
(540~560 Models)	:	173mm x 68mm x 33mm
(580 Models)	:	213mm x 68mm x 33mm
Weight (500~520 Models)	:	200g (include batteries)
(540~560 Models)	:	240g (include batteries)
(580 Models)	:	290g (include batteries)

Receiver Unit

Frequency Range	:	433 MHz
Channel Spacing	:	25KHz
Hamming Distance	:	6
Frequency Control	:	Synthesizer (PLL)
Frequency Drift	:	< 5ppm @ -10°C ~ +70°C
Frequency Deviation	:	< 1ppm @ 25°C
Sensitivity	:	-120dBm
Antenna Impedance	:	50ohms
Data Decoder Reference	:	Quartz Crystals
Responding Time	:	40ms (Normal)
Enclosure Rating	:	IP-65 (Alpha 500~560 Models) IP-66 (Alpha 580 Models)
Source Voltage	:	AC 24V、42V、48V、110~240V、380V @ 50/60 Hz. DC 12~24V
Power Consumption	:	11VA
Operating Temperature	:	-10°C ~ +70°C
Output Contact Rating	:	250V @ 10A
Dimension (500~560 Models)	:	310mm x 134mm x 72mm
(580 Models)	:	300mm x 230mm x 86mm
Weight (500~520 Models)	:	1,625g (include output cable)
(540~560 Models)	:	1,700g (include output cable)
(580 Models)	:	3,400g (no output cable)

12. PARTS LIST

1.	433 MHz Transmitting RF Board (All Models)	BTX433
2.	Encoder Board (Alpha 500)	BEN500
	Encoder Board (Alpha 520)	BEN520
	Encoder Board (Alpha 540S)	BEN540S
	Encoder Board (Alpha 540A)	BEN540A
	Encoder Board (Alpha 560S)	BEN560S
	Encoder Board (Alpha 560A)	BEN560A
	Encoder Board (Alpha 580A-1)	BEN580A1
	Encoder Board (Alpha 580A-2)	BEN580A2
	Encoder Board (Alpha 580B)	BEN580B
	Encoder Board (Alpha 580C-1)	BEN580C1
	Encoder Board (Alpha 580C-2)	BEN580C2
	Encoder Board (Alpha 580D)	BEN580D
	Encoder Board (Alpha 580E)	BEN580E
	Encoder Board (Alpha 580F)	BEN580F
3.	433 MHz Receiving RF Module (All Models)	BRX433
4.	Decoder/Relay Board (Alpha 500)	BDR500
	Decoder/Relay Board (Alpha 520)	BDR520
	Decoder/Relay Board (Alpha 540S)	BDR540S
	Decoder/Relay Board (Alpha 540A)	BDR540A
	Decoder/Relay Board (Alpha 560S)	BDR560S
	Decoder/Relay Board (Alpha 560A)	BDR560A
	Decoder/Relay Board (Alpha 580A-1)	BDR580A1
	Decoder/Relay Board (Alpha 580A-2)	BDR580A2
	Decoder/Relay Board (Alpha 580B)	BDR580B
	Decoder/Relay Board (Alpha 580C-1)	BDR580C1
	Decoder/Relay Board (Alpha 580C-2)	BDR580C2
	Decoder/Relay Board (Alpha 580D)	BDR580D
	Decoder/Relay Board (Alpha 580E)	BDR580E
	Decoder/Relay Board (Alpha 580F)	BDR580F
5.	Transmitter Enclosure (Alpha 500 & 520 Models)	BCT500
	Transmitter Enclosure (Alpha 540S & 560S Models)	BCT560S
	Transmitter Enclosure (Alpha 540A & 560A Models)	BCT560A
	Transmitter Enclosure (Alpha 580A, C, D Models)	BCT580A
	Transmitter Enclosure (Alpha 580B, E, F Models)	BCT580B
6.	Receiver Enclosure (Alpha 500 & 520 Models)	BCR500
	Receiver Enclosure (Alpha 540 & 560 Models)	BCR560
	Receiver Enclosure (Alpha 580 Models)	BCR580

7.	Double-Step Pushbutton (All Models)	B50001
	Single-Step Pushbutton (All Models)	B50002
8.	EMS Red Cap (All Models)	EMS01
9.	Wrist Strap (Alpha 500 ~ 560 Models)	WS01
	Waist Belt (Alpha 580 Models)	WB01
10.	Pushbutton Rubber Boot (Alpha 500 & 520 Models)	PRB01
	Pushbutton Rubber Boot (Alpha 540 & 560 Models)	PRB02
	Pushbutton Rubber Boot (Alpha 580 Models)	PRB03
11.	Pushbutton Direction labels (All Types)	DL01
12.	Transformer (12/24VDC – Alpha 500 ~ 560 Models)	T24VDC
	Transformer (24VAC – Alpha 500 ~ 560 Models)	T24VAC
	Transformer (48VAC – Alpha 500 ~ 560 Models)	T48VAC
	Transformer (110/120VAC – Alpha 500 ~ 560 Models)	T120VAC
	Transformer (220/230 VAC – Alpha 500 ~ 560 Models)	T230VAC
	Transformer (380VAC – Alpha 500 ~ 560 Models)	T380VAC
	Transformer (12/24VDC – Alpha 580 Models)	SSB-2601
	Transformer (AC 110V~120V / 220V~240V – Alpha 580 Models)	SSB-2603
	Transformer (AC 350V~380V / 400V~460V – Alpha 580 Models)	SSB-2604
	Transformer (AC 24V/32V/46V/48V – Alpha 580 Models)	SSB-2665
13.	Regular Output Contact Relay (All Models)	RLY01
	Safety MAIN Contact Relay (All Models)	RLY02
14.	Protective Vinyl Casing (Alpha 500 ~ 560 Models)	VPC01
	Protective Vinyl Casing (Alpha 540 ~ 560 Models)	VPC02
15.	Leather Pouch (Alpha 500 ~ 520 Models)	LP500
	Leather Pouch (Alpha 540 ~ 560 Models)	LP560
16.	2-meter Output Cable with 1 Common Circuit (Alpha 500 ~ 560 Models)	OC500
	2-meter Output Cable with 1 Common Circuit (Alpha 540 ~ 560 Models)	OC501
	2-meter Output Cable with 2 Common Circuits (Alpha 540 ~ 560 Models)	OC502
	2-meter Output Cable with 3 Common Circuits (Alpha 500 ~ 520 Models)	OC503
	2-meter Output Cable with 4 Common Circuits (Alpha 540 ~ 560 Models)	OC504
17.	Receiver Mounting Spring + Hardware (Alpha 500 ~ 560 Models)	RMS500
	Receiver Shock Absorbers + Mounting Hardware (Alpha 580 Models)	RSA580
18.	Optional External 433 MHz Antenna (All Models)	ANT433
19.	BNC Jack for External Antenna Connection (Alpha 500 ~ 560 Models)	BNC500
	BNC Jack for External Antenna Connection (Alpha 580 Models)	BNC580
20.	BNC Lead Wire for External Antenna Connection	BLW500
21.	2-meter Coaxial Cable for External Antenna Connection (All Models)	CC500
22.	Removable Transmitter Power Key (All Models)	KEY01